



AN ADAPTIVE CONTROLLED HYBRID ACTIVE POWER FILTER FOR POWER QUALITY IMPROVEMENT WITH NON-LINEAR LOAD GRID SYSTEM

Rahul Shrivastava¹, Rahul Malviya²

¹Research Scholar, Department of Electrical and Electronics Engineering,
IES College of Technology, Bhopal

²Assistant Professor, Department of Electrical and Electronics Engineering,
IES College of Technology, Bhopal

Email:-rsrivastava207@gmail.com¹, rahul.sirt2009@gmail.com²

ABSTRACT

Shunt active power filters (SAPFs) implemented without harmonic detection schemes are susceptible to sudden load variations. This paper proposes a robust control strategy to reduce this drawback. In this strategy, the dc-link voltage is regulated by a hybrid control technique combining a standard proportional–integral PI and a sliding-mode (SM) controllers. The SM scheme continuously determines the gains of the PI controller based on the control loop error and its derivative. The chattering due to the SM scheme is reduced by a transition rule that fixes the controller gains when steady-state condition is reached. This controller is termed as dual-sliding-mode-proportional–integral. The phase currents of the power grid are indirectly regulated by double-sequence controllers with two degrees of freedom, where the internal model principle is employed to avoid reference frame transformation. The proposed control strategy ensures zero steady-state error and improves the performance under hard transients such as load variation. The modelling is done in MATLAB Simulink environment with graphs plotted with respect to time using GUI environment.

Keywords: sliding mode controller with PI Dual sliding mode controller with PI, Nonlinear load, shunt active power filter. MATLAB 2016

I INTRODUCTION

Electrical power quality has been a developing concern because of the proliferation of the nonlinear loads, which causes significant increase of line losses, instability and voltage distortion [1]. With injection of harmonic current into the system, those nonlinear loads additionally motive low electricity component. The ensuing unbalanced current adversely affects each component inside the energy system and equipment. This outcomes in terrible power aspect, increased losses, excessive neutral currents and reduction in standard efficiency.

Customarily, passive power filters have been utilized as a remunerating gadget, to repay mutilation produced by consistent non-straight loads. These filters [2] are intended to give a low impedance way to harmonics and keeping up great power quality with a most straightforward structure and ease. Notwithstanding, latent filters have a few faults like mistuning, reverberation, reliance on the states of the power supply system and huge estimations of detached segment that prompting cumbersome usage. For astounding power necessities, various topologies of active filters for example APF associated in arrangement or in parallel (arrangement active filters and shunt active filters) to the nonlinear loads with the point of improving voltage or current bending. These filters are the most broadly utilized arrangement, as they efficiently dispose of current contortion and the reactive power created by non-straight loads.

1.1 POWER SYSTEM HARMONICS

Power system harmonics are whole number products of the basic power system recurrence. Power system harmonics are made by non-straight gadgets associated with the power system. Harmonics are voltage and current frequencies riding over the ordinary sinusoidal voltage and current waveforms. The nearness of harmonics (both current and voltage) is seen as 'contamination' influencing the activity of power systems.

The harmonics created by the most well-known non-linear loads have the accompanying properties:

- Lower request harmonics will in general overwhelm in adequacy
- If the waveform has half-wave symmetry there are no even harmonics
- Harmonic outflows from an enormous number of non-direct loads of a similar sort will be included.

Harmonics in power systems can turn into the wellspring of an assortment of unwelcome impacts. For instance, harmonics can cause signal impedance, over voltages, information misfortune, and electrical switch disappointment, just as hardware warming, glitch, and harm. Any distribution circuit serving present day electronic gadgets will contain some level of symphonious frequencies. The more prominent the power drawn by nonlinear loads, cause more noteworthy the dimension of voltage bending. Potential issues (or side effects of issues) ascribed to harmonics include:

- Malfunction of delicate gear
- Random stumbling of circuit breakers
- Flickering lights
- Very high impartial currents
- Overheated stage conductors, boards, and transformers

II. HYBRID ACTIVE POWER FILTERS

Specialized confinements of traditional APFs can be overwhelmed with half and half APF designs. They are commonly the mix of essential APFs and uninvolved filters. Crossover APFs, acquiring the upsides of both aloof filters and APFs give improved execution and financially savvy arrangements. The thought behind this plan is to at the same time lessen the exchanging clamor and electromagnetic obstruction.

The possibility of half and half APF has been proposed by a few scientists. In this plan, a minimal effort uninvolved high-pass filter (HPF) is utilized notwithstanding the ordinary APF. The harmonics filtering task is separated between the two filters. The APF drops the lower request harmonics, while the HPF filters the higher request harmonics. The fundamental target of cross breed APF, along these lines is to improve the filtering execution of high-request harmonics while giving a practical low request harmonics alleviation.

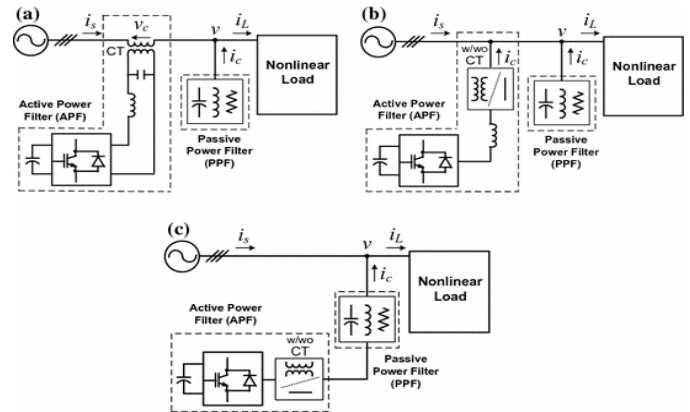

Fig.2.1: Hybrid Active power filter

III CONTROL STRATEGIES

3.1 INTRODUCTION

Fig. 3.1 demonstrates the schematic chart of the control and power circuit of 3-stage HSAPF. The SAPF comprises of a voltage source inverter associated with the matrix through a LC filter and a three-stage direct transformer.

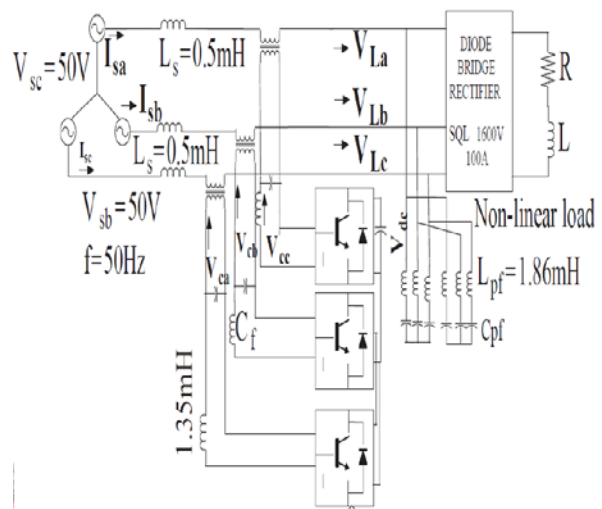

Fig.3.1: Proposed topology

The topology of HSAPF is made out of an arrangement associated active power filter (SAPF) and a shunt associated latent power

filter (PPF). PPF associated in parallel with the load. The PPF comprises of fifth, seventh tuned LC filter of rating ($L_{pf} = 1.86\text{mH}$ and $C_{pf} = 60\mu\text{F}$) for the pay of consonant current on load side. The SAPF associated in arrangement with the source through a coordinating transformer of turn proportion 1:2 to guarantee galvanic seclusion. SAPF comprises of three sections, for example, three stage IGBT based SEMIKRON inverter, a DC-connect capacitor of $2200\mu\text{F}$ and a three-stage high recurrence LC filter of impedances ($C_f = 60\mu\text{F}$, $L_f = 1.35\text{mH}$). The high recurrence LC filter is connected to dispose of high recurrence changing swells from the remunerating voltage provided by the inverter. A non-direct load involving a three stage diode connect rectifier (ABC 100V 100A) with RL-load (i.e.resistor of 8.5A, 100 and inductor of 40mH) is considered.

IV SLIDING MODE AND DUAL SLIDING -PI CONTROLLER SCHEME

In control systems, sliding mode control (SMC) is a nonlinear control technique that modifies the elements of a nonlinear system by use of an irregular control signal (or all the more thoroughly, a set-esteemed control signal) that powers the system to "slide" along a cross-segment of the system's typical conduct. The state-input control law is definitely not a persistent capacity of time. Rather, it can change starting with one persistent structure then onto the next dependent on the current position in the state space. Subsequently, sliding mode control is a variable structure control strategy. The various control structures are planned so directions dependably advance toward a neighboring locale with an alternate control structure, thus a definitive direction won't exist completely inside one control structure. Rather, it will slide along the limits of the control structures. The movement of the system as it slides along these limits is known as a sliding mode [1] and the geometrical locus comprising of the limits is known as the sliding (hyper)surface. With regards to current control hypothesis, any factor structure system, similar to a system under SMC, might be seen as an exceptional instance of a half breed dynamical system as the system the two moves through a consistent state space yet in addition travels through various discrete

As of late the majority of the controlled systems are driven by electricity as it is one of the cleanest and most effortless (with smallest time consistent) to change (controllable) energy source. The change of electrical energy is illuminated by power hardware. A standout amongst the most trademark regular highlights of the power electronic gadgets is the exchanging mode. We can turn on and off the semiconductor components of the power electronic gadgets so as to diminish misfortunes supposing that the voltage or current of the exchanging component is about zero, at that point the misfortune is likewise close to zero. Along these lines, the power electronic gadgets have a place commonly with the gathering of variable structure systems (VSS). The variable structure systems make them intrigue attributes in charge hypothesis. A VSS may likewise be asymptotically steady if every one of the components of the VSS are temperamental itself. Another significant element that a VSS - with suitable controller - may get in a state where the elements of the system can be portrayed by a differential condition with lower level of opportunity than the first one. In this express the system is hypothetically totally autonomous of changing certain parameters and of the impacts of certain outside unsettling influences (for example non-direct load). This state is called sliding mode and the control dependent on this is called sliding mode control which has a significant job in the control of power electronic gadgets.

As per the hypothesis sliding mode control ought to be hearty, yet analyzes demonstrate that it has genuine restrictions. The fundamental issue by applying the sliding mode is the high recurrence swaying around the sliding surface, the purported prattling, which emphatically lessens the control execution. No one but few could actualize practically speaking the hearty conduct anticipated by the hypothesis. Many have inferred that the nearness of chattering makes sliding mode control a decent hypothesis diversion, which isn't material practically speaking. In the following time frame the analysts put a large portion of their energy in jabbering free applications, building up various arrangements.

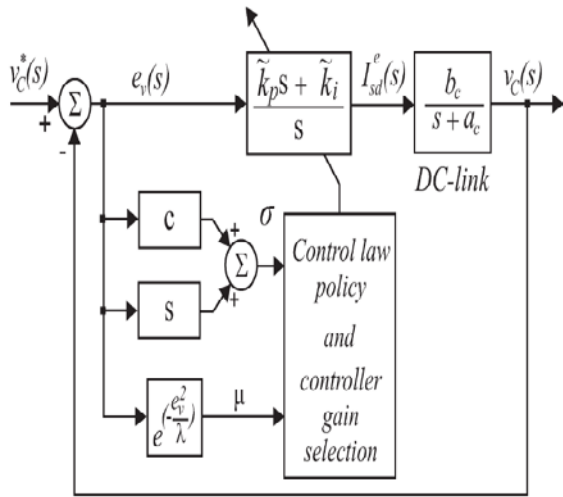

Fig.5.1: Block diagram of the DSM – PI control scheme.

V DC LINK VOLTAGE CONTROLLER

The proposed control conspires for the dc connect is executed by a nonstandard vigorous SM – PI, which is actualized by a proportional–Integral (PI) controller in which its controller gains are determined by utilizing the SMC approach dependent on the sliding surface formed by the control circle blunder and its subordinate. The prattling because of the SMC conspire is diminished by a progress plot, which fixes the controller picks up when system relentless state is come to. The incorporation of this change plot in the SM – PI controller results in another controller that is named here as DSM – PI.

5.1 SM – PI Control Scheme: Consider the dynamic model of the dc connection of the SAPF depicted by (3) with the estimation of esr ignored. Conceding that the SM – PI controller exchange capacity can be composed as

$$C_v(s) = \frac{\widetilde{k}_p s + \widetilde{k}_i}{s} \quad (4.1)$$

controller gains are determined by SMC theory. The closed loop dynamics of the dc-link voltage can be described as follows

$$V_c(s) = \frac{b_c \widetilde{k}_p (s + \frac{\widetilde{k}_i}{\widetilde{k}_p})}{s^2 + (a_c + b_c \widetilde{k}_p)s + b_c \widetilde{k}_i} V_c^*(s) \quad (4.2)$$

Amid the transient express, the addition k_p switches between $k_p^{av} + 2k_p^+$ and $k_p^{av} - 2k_p^+$. After achieving the relentless state, \widetilde{k}_p is kept

consistent at k_p^{av} . A comparable proclamation applies to k_i . Soundness of the dc interface is guaranteed at whatever point air conditioning

$$a_c + b_c \widetilde{k}_p > 0 \quad (4.3)$$

$$b_c \widetilde{k}_i > 0 \quad (4.4)$$

By utilizing an appropriate structure strategy, these conditions can be effectively fulfilled.

Define a sliding surface depicted by

$$\sigma = c e_v + \dot{e}_v \quad (4.5)$$

where $e_v = v_c^* - v_c$, \dot{e}_v is its subsidiary, and c is a positive steady.

To demonstrate the dependability of the proposed SM – PI at the beginning ($\sigma = 0$), let the Lyapunov competitor be

$$V(e_v) = \frac{1}{2} e_v^2 \quad (4.6)$$

Accordingly, its time subsidiary can be communicated as

$$\dot{V}(e_t) = e_v \dot{e}_v = e_v (-c e_v) = -c e_v^2 < 0. \quad (4.7)$$

Since steady c is certain, the proposed control is asymptotically steady. In view of these soundness confinements, the controller additions can be dictated by utilizing the accompanying exchanging laws:

$$\widetilde{k}_p = [(1 + \text{sgn}(\sigma)) k_p^+ - (1 - \text{sgn}(\sigma)) k_p^-] + k_p^{av} \quad (4.8)$$

$$\widetilde{k}_i = [(1 + \text{sgn}(\sigma)) k_i^+ - (1 - \text{sgn}(\sigma)) k_i^-] + k_i^{av} \quad (4.9)$$

where k_p^+ , k_p^- , k_i^+ , k_i^- , k_p^{av} , and k_i^{av} are sure constants decided as an element of the ideal system execution (these increases can be acquired by utilizing a standard PI structure approach, e.g., root locus). The scientific capacity $\text{sgn}(\sigma)$ restores the qualities 1 for $\sigma > 0$ or -1 for $\sigma < 0$.

5.2 DSM – PI CONTROL SCHEME:

The SM – PI controller has a decent exhibition amid the transient state however has an undesired symptom when the consistent state is come to. It is the prattling begun by the SMC exchanging laws utilized for figuring the

controller gains. This can be relieved if the controller additions can be fixed in unfaltering state (which results in a standard PI controller). It very well may be gotten by utilizing a progress rule in the controller structure. For this, consider a Gaussian capacity defined as

$$\mu(e_v) = e^{-\frac{e_v^2}{\lambda}} \quad (4.10)$$

where μ is the choice variable to choose between the exchanging and fixed controllers, e_v is the dc-interface voltage mistake, and λ is the parameter of the Gaussian capacity. Defining a scope of qualities around the reference voltage of the dc interface, i.e., Δe_t , it is conceivable to compute the estimation of $\mu_t = \mu(e_t)$, from which the controller increases of SM – PI are fixed (i.e., $k_p = k_p^{av}$ and $k_i = k_i^{av}$), as showed in Fig. 4.2. In this chart, the esteem μ_t speaks to the limit identified with voltage blunder e_t where the controller progress must happen.

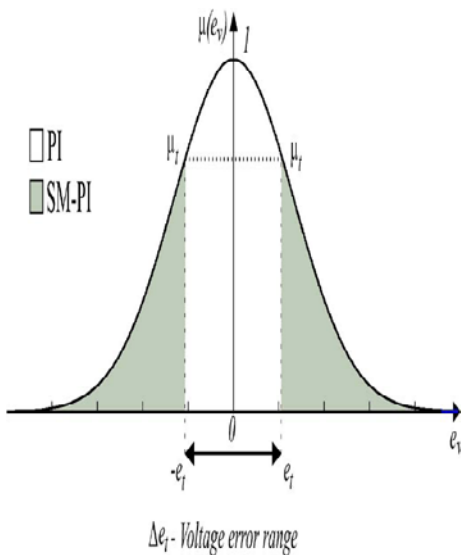

Fig 5.3 Graph of the transition criterion μ .

Along these lines, the progress functions as pursues: By utilizing (4.10), the estimation of $\mu(e_v)$ is ceaselessly determined for every mistake voltage e_v . On the off chance that this esteem is smaller than μ_t , the actualized controller is the SM – PI; else, it is utilized a standard PI with antiwindup (controller SM – PI with fixed gains). To make this change smooth, it is important to sufficiently modify parameter λ . The higher λ , the less touchy is μ to the voltage blunder e_v ; generally, the smaller λ , the more delicate will be μ to the voltage mistake e_v . the square graph of the proposed DSM – PI controller, In which, the DSM – PI

controller gains k_p and k_i are controlled by exchanging laws of \tilde{k}_p (4.8) and \tilde{k}_i (4.9) acquired from the sliding surface dictated by squares c and s.

VI SIMULATION MODEL AND RESULTS

6.1 Working of the model

- 1) The simulation is connected with a three phase source connected to impedance.
- 2) A non-linear load is connected which has diode bridge rectifier connected to RL load.
- 3) The series active power filter is connected at point of common coupling using series transformers.
- 4) Each single-phase inverter is controlled individually using feedback controller.
- 5) The controller comprises of dual sliding mode controller with voltage and current feedback.
- 6) The complete simulation is run for 1sec with and without active power filter.
- 7) The DSM-PI controller uses adjustable Kp and Ki values for the series active power filter to react faster to the disturbances caused by the non-linear load.
- 8) An FFT analysis is carried out from powergui block and compared with response time between PI and DSM-PI controllers.

6.2 SIMULATION MATLAB MODEL

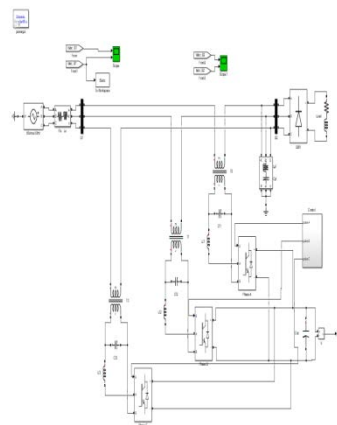

Fig. 6.1 Simulink model of test system Sliding PI Mode HSAPF

The above is the grid system which is modelled without HSAPF connected to non-linear load which generates harmonics.

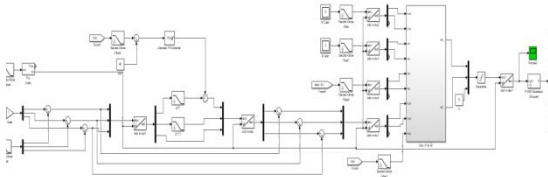

Fig. 6.2 : Internal sub system of SM- PI controller

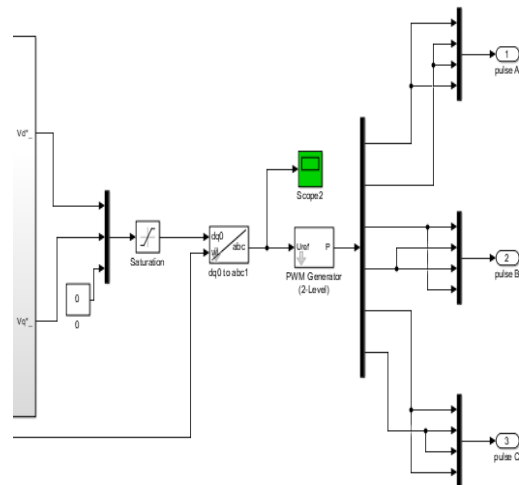

Fig. 6.5: Pulse generation for HSAPF IGBTs

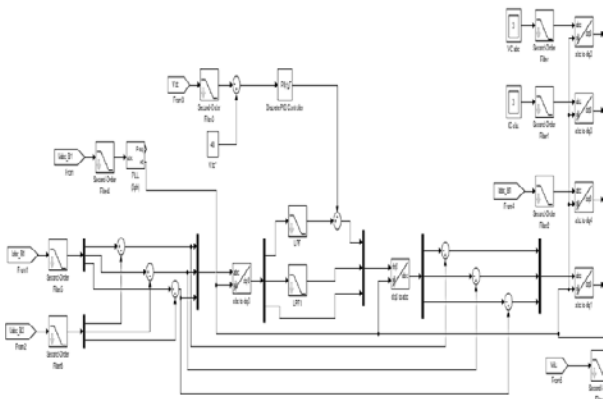

Fig. 6.3: Reference dq component generation using PI controller

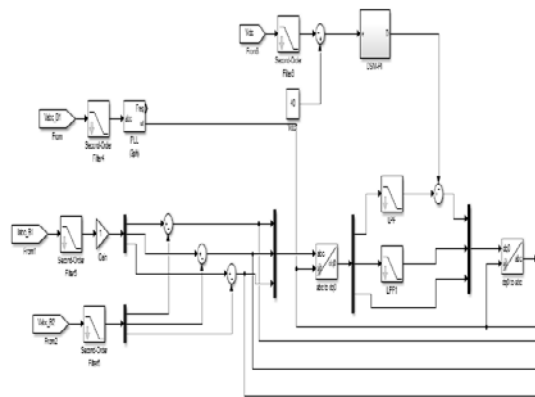

Fig. 6.6: Reference dq component generation using DSM-PI controller

6.3 DUAL SLIDING MODE –PI CONTROL SIMULATION MODEL

The DC voltage PI controller is updated DSM-PI controller connected to the comparison.

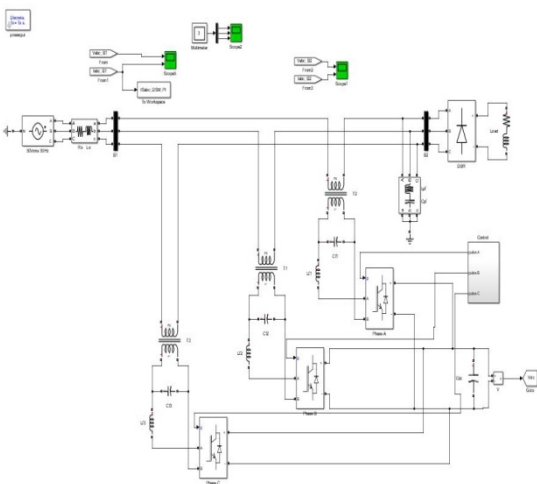

Fig.6.4: Simulink model of test system with Dual sliding PI Mode HSAPF

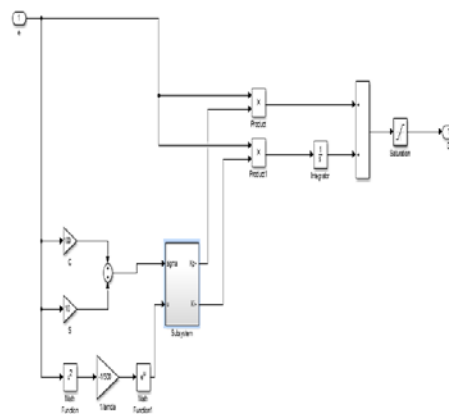

Fig.6.7: MATLAB Simulink model for DSM-PI controller

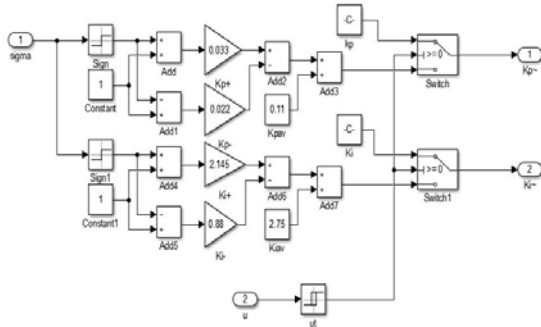

Fig.6.8: MATLAB Simulink model for DSM-PI controller developed equation

The Input source Voltage (V_s) and Source Current (I_s) for the DSM-PI model are shown below

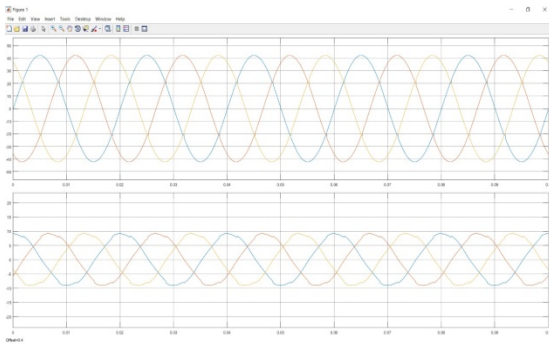

Fig 6.9: Input Waveforms, V_s and I_s for DSM-PI controller model

The Output Voltage and Source Current for the DSM-PI model are shown below

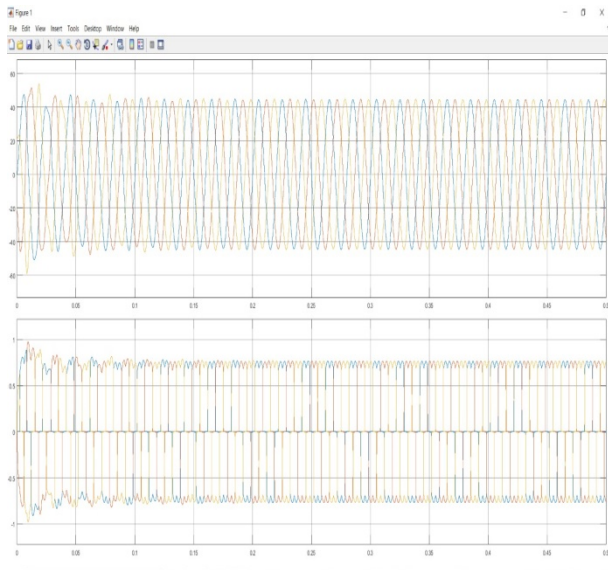

Fig 6.10: Input Waveforms, V_s and I_s for DSM-PI controller model

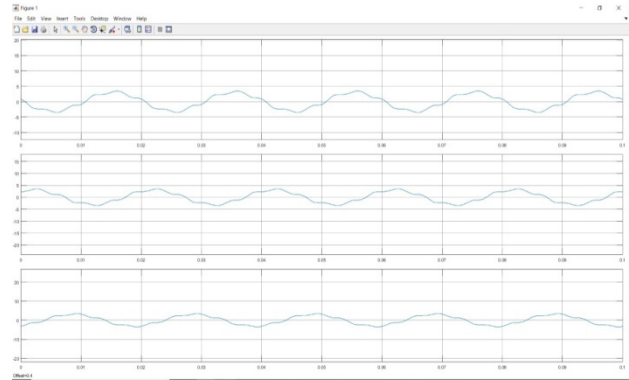

Fig 6.11: Compensative voltage for the proposed controller based HSAPF system

6.4 THD COMPARISONS

THD Comparisons of SMC and DSM-PI models are compared below.

TIME(Sec)	SM-PI(%)	DSM-PI(%)
0	57.03	34.88
0.1	18.76	7.68
0.2	5.29	3.77
0.3	3.58	3.44

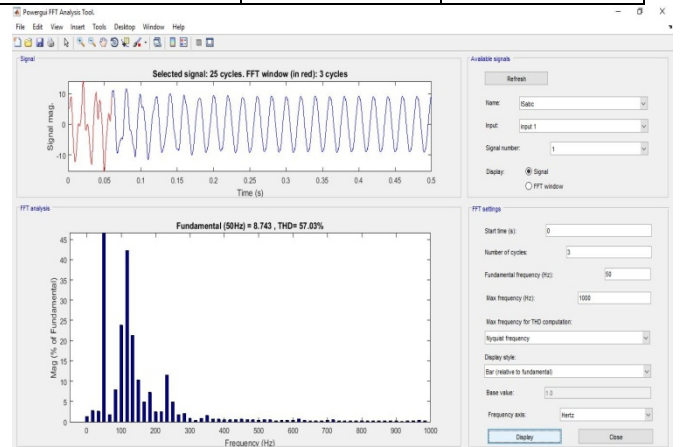

Fig 6.11 FFT analysis of SM-PI controller at 0 sec

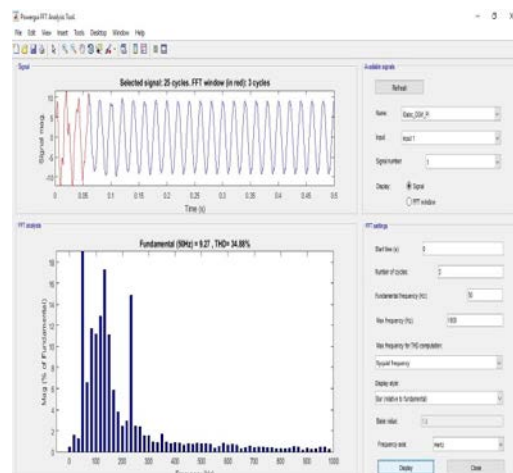

Fig 6.12 FTT analysis of DSM-PI controller at 0 sec

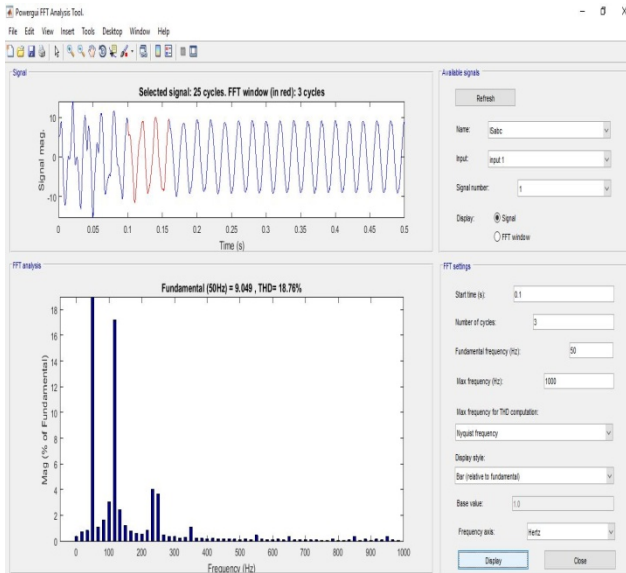

Fig 6.13 FFT analysis of SM-PI controller at 0.1 sec

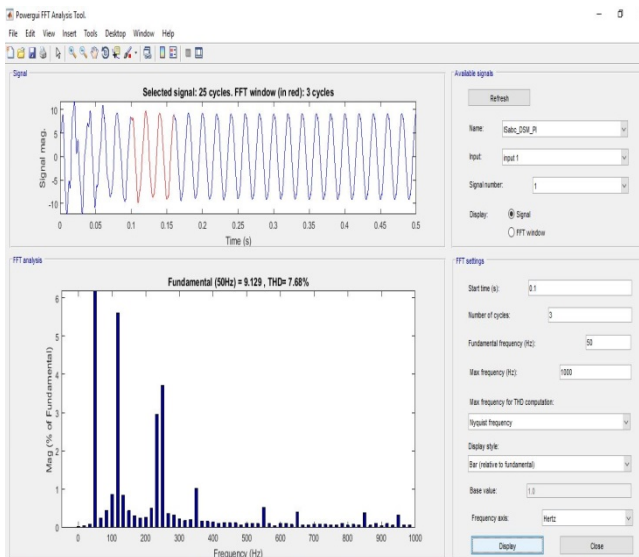

Fig 6.14 FFT analysis of DSM-PI controller at 0.1 sec

VI CONCLUSION AND FUTURE SCOPE

In this paper, another hearty controller plan for HSAPF has been exhibited. The control configuration is set up by sliding mode controller-2 that determines the identical control law. This control law is especially useful for exchanging design age. The strong ness of the proposed controller has been verified by investigating the presentation under relentless state just as transient state of the power system. With the utilization of this method, the functionalities of the HSAPF are improved. From the got recreations just as exploratory outcomes, the proposed HSAPF has been seen to give efficient current just as voltage symphonious moderation, reference voltage tracking conduct, and reactive power pay with

progressively shifting load conditions. Within the sight of an added substance background noise, misfortunes and bending in both source current just as load voltage, SRF technique is observed to be the best one for reference age. Moreover, the primary component of sliding mode controller-2 is the variable structure control strategy, which diminishes tracking mistake mutilation, smother prattling, commotion and henceforth an ideal increase security of the HSAPF system has been accomplished. The proposed filter can repay source currents and furthermore alter itself to adjust for varieties in non-direct load currents, keep up dc-interface voltage at unflinching state and aides in the remedy of power factor of the supply side adjoining solidarity. Reenactment and exploratory outcomes under a few system working states of load has verified the plan idea of the recommended sliding mode based HSAPF to be exceedingly successful.

VII REFERENCES

- [1] Z. Zeng, H. Yang, S. Tang, and R. Zhao, "Objective-oriented power quality compensation of multifunctional grid-tied inverters and its application in microgrids," *Power Electronics, IEEE Transactions on*, vol. 30, no. 3, pp. 1255–1265, 2015.
- [2] A. B. Nassif, W. Xu, and W. Freitas, "An investigation on the selection of filter topologies for passive filter applications," *Power Delivery, IEEE Transactions on*, vol. 24, no. 3, pp. 1710–1718, 2009.
- [3] M. Ali, E. Laboure, and F. Costa, "Integrated active filter for differential-mode noise suppression," *Power Electronics, IEEE Transactions on*, vol. 29, no. 3, pp. 1053–1057, 2014.
- [4] E. R. Ribeiro and I. Barbi, "Harmonic voltage reduction using a series active filter under different load conditions," *Power Electronics, IEEE Transactions on*, vol. 21, no. 5, pp. 1394–1402, 2006.
- [5] F. Z. Peng, H. Akagi, and A. Nabae, "A new approach to harmonic compensation in power systems—a combined system of shunt passive and series active filters," *Industry Applications, IEEE Transactions on*, vol. 26, no. 6, pp. 983–990, 1990.

- [6] S. Diptimayee Swain, P. K. Ray, and K. Mohanty, "Voltage compensation and stability analysis of hybrid series active filter for harmonic components," in India Conference (INDICON), 2013 Annual IEEE, pp. 1–6, IEEE, 2013.
- [7] W. Tangtheerajaronwong, T. Hatada, K. Wada, and H. Akagi, "Design and performance of a transformerless shunt hybrid filter integrated into a three-phase diode rectifier," *Power Electronics, IEEE Transactions on*, vol. 22, no. 5, pp. 1882–1889, 2007.
- [8] high-voltage transformerless hybrid shunt active power filter," in *Industrial Electronics and Applications, 2009. ICIEA 2009. 4th IEEE Conference on*, pp. 2908–2913, IEEE, 2009.
- [9] B. Kedjar and K. Al-Haddad, "Dsp-based implementation of an lqr with integral action for a three-phase three-wire shunt active power filter," *Industrial Electronics, IEEE Transactions on*, vol. 56, no. 8, pp. 2821–2828, 2009.
- [10] R. Panigrahi, B. Subudhi, and P. C. Panda, "A robust lqg servo control strategy of shunt-active power filter for power quality enhancement," *Power Electronics, IEEE Transactions on*, vol. 31, no. 4, pp. 2860–2869, 2016.
- [11] L. M. Fridman, "Singularly perturbed analysis of chattering in relay control systems," *IEEE Transactions on Automatic Control*, vol. 47, no. 12, pp. 2079–2084, 2002.
- [12] M. A. Mulla, R. Chudamani, and A. Chowdhury, "A novel control method for series hybrid active power filter working under unbalanced supply conditions," *International Journal of Electrical Power & Energy Systems*, vol. 64, pp. 328–339, 2015.
- [13] S. Rahmani, K. Al-Haddad, and H. Y. Kanaan, "Average modeling and hybrid control of a three-phase series hybrid power filter," in *Industrial Electronics, 2006 IEEE International Symposium on*, vol. 2, pp. 919–924, IEEE, 2006.
- [14] S. D. Swain and P. K. Ray, "Harmonic current and voltage compensation using hsapf based on hybrid control approach for synchronous reference frame method," *International Journal of Electrical Power & Energy Systems*, vol. 75, pp. 83–90, 2016.
- [15] H. De Battista and R. J. Mantz, "Harmonic series compensators in power systems: their control via sliding mode," *Control Systems Technology, IEEE Transactions on*, vol. 8, no. 6, pp. 939–947, 2000.