



ZIGBEE BASED WIRELESS ELECTRONIC NOTICEBOARD

Amrutha K R¹, Resmi K Rajan²

¹Vidya Academy of Science & Technology, Thrissur

²Assistant professor, Vidya Academy of Science & Technology, Thrissur

¹amruthakr95@gmail.com, ²resmi.k.r@vidyaacademy.ac.in

Abstract

This paper is designed to develop a PC controlled message display for notice board. It can also be used to display latest information anywhere such as colleges, shops, railway stations and other places. The information is transmitted using PC. Traditionally notice board is all about sticking information, but sticking various notices day-to-day is a difficult process. A person is required separately to take care of this notice board. This system displays notices through a PC on notice boards.

This system can be implemented in many important places where latest information can be displayed. For example if implemented in colleges all information for students can be displayed. It is very convenient for students and college management to display any information. This system can also be implemented in railway stations and airports to display information regarding the train and flight timings. This system reduces the wastage of papers. The information is sent through a PC. The data is serially transmitted and received through Arduino. We are using AT89S51 microcontroller. The data is wirelessly transmitted through a zigbee dongle and received through another zigbee which is interfaced to the microcontroller. The message is displayed through a 16*2 LCD display.

Index Terms: Wireless, Electronic notice board, ZigBee

I. INTRODUCTION

The aim is to develop a noticeboard which displays messages wirelessly. Wireless

communications is, by any measure, the fastest growing segment of the communications industry. As such, it has captured the attention of the media and the imagination of the public. Cellular systems have experienced exponential growth over the last decade and there are currently around two billion users worldwide. Indeed, cellular phones have become a critical business tool and part of everyday life in most developed countries, and are rapidly supplanting antiquated wireline systems in many developing countries. In addition, wireless local area networks currently supplement or replace wired networks in many homes, businesses, and campuses.

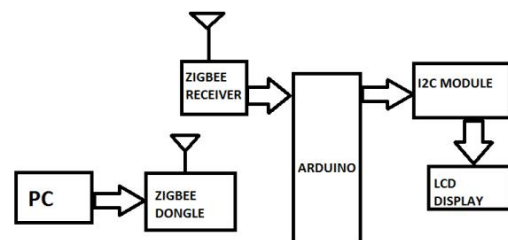

Fig. 1. Block Diagram

Many new applications, including wireless sensor networks, automated highways and factories, smart homes and appliances, and remote telemedicine, are emerging from research ideas to concrete systems. The explosive growth of wireless systems coupled with the proliferation of laptop and palmtop computers indicate a bright future for wireless networks, both as stand-alone systems and as part of the larger networking infrastructure. However, many technical challenges remain in designing robust wireless networks that deliver the performance necessary to support emerging applications.

As radios decrease their cost and power consumption, it becomes feasible to embed them in more types of electronic devices, which can be used to create smart homes, sensor networks, and other compelling applications. Two radios have emerged to support this trend: Bluetooth and Zigbee. The ZigBee radio specification is designed for lower cost and power consumption than Bluetooth. The specification is based on the IEEE 802.15.4 standard. The radio operates in the same ISM band as Bluetooth, and is capable of connecting 255 devices per network. The specification supports data rates of up to 250 Kbps at a range of up to 30 m. These data rates are slower than Bluetooth, but in exchange the radio consumes significantly less power with a larger transmission range. The goal of ZigBee is to provide radio operation for months or years without recharging, thereby targeting applications such as sensor networks and inventory tags.

II. CIRCUIT DIAGRAM

The circuit is drawn using Proteus-ISIS Professional v7.7. When we sent message from a PC, it transmits the message through Zigbee dongle. Zigbee receiver, which is arranged at the display unit, receives the message. Now the controller reads the message from the receiver and displays on the LCD.

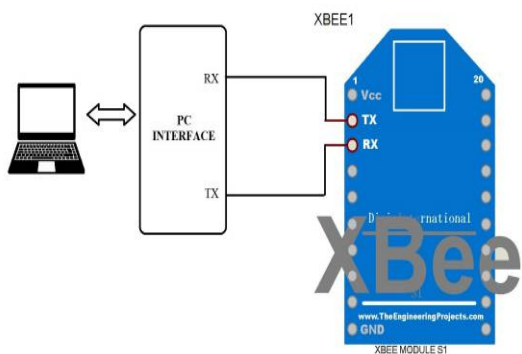

Fig. 2. Circuit Diagram Transmitter Section

III. HARDWARE AND SOFTWARE

The block diagram of wireless notice board is the transmitter side and the receiver side. In the transmitter side we are using the VB.NET language by using the X-CTU software. Here the max 232 IC is used to interfacing with the microcontroller 8051 and the receiver side it displays the message on the board.

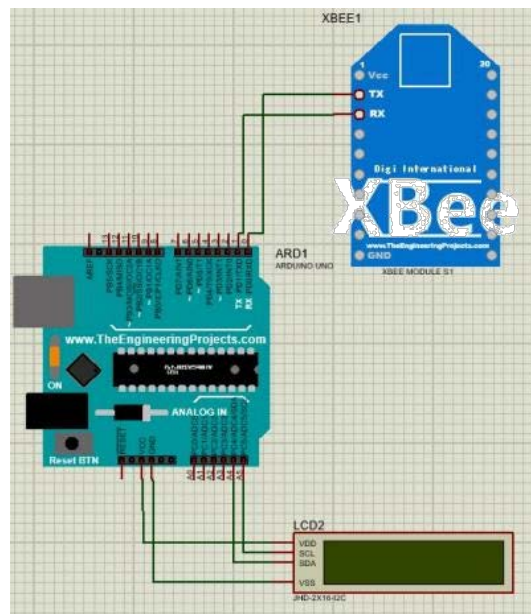

Fig. 3. Circuit Diagram Receiver Section

A. Zigbee Receiver

ZigBee is an IEEE 802.15.4-based specification for a suite of high-level communication protocols used to create personal area networks with small, low-power. Its low power consumption limits transmission distances to 10100 meters line-of-sight, depending on power output and environmental characteristics. ZigBee devices can transmit data over long distances by passing data through a mesh network of intermediate devices to reach more distant ones. ZigBee has a defined rate of 250 kbit/s, best suited for intermittent data transmissions from a sensor or input device.

B. I2C Module

This is another great blue/yellow backlight LCD display. As the pin resources of Arduino controller is limited, your project may be not able to use normal LCD shield after connected with a certain quantity of sensors or SD card. However, with this I2C interface LCD module, you will be able to realize data display via only 2 wires. If you already has I2C devices in your project, this LCD module actually cost no more resources at all. It is fantastic for Arduino based project. IC (InterIntegrated Circuit), pronounced I-squared-C, is a synchronous, multimaster, multi-slave, packet switched, single-ended, serial computer bus invented in 1982 by Philips Semiconductor (now NXP Semiconductors). It is widely used for attaching lower-speed

peripheral ICs to processors and microcontrollers in short-distance, intra-board communication. Alternatively IC is spelled I²C (pronounced I-two-C) or IIC (pronounced I-I-C).

C. X-CTU

Module of XBEE Series2 of Digi Inc. [4] has been used. The Xbee radios are programmed using X-CTU software in API mode with the desired baud rate. Screenshots of X-CTU are shown in Fig. 6. A .Net based GUI application is developed on PC which enables the user to display message. The application authenticates user and then allows to display message.

D. Arduino Software

The Arduino Integrated Development Environment - or Arduino Software (IDE) - contains a text editor for writing code, a message area, a text console, a toolbar with buttons for common functions and a series of menus. It connects to the Arduino and Genuino hardware to upload programs and communicate with them. Programs written using Arduino Software (IDE) are called sketches. These sketches are written in the text editor and are saved with the file extension .ino. The editor has features for cutting/pasting and for searching/replacing text. The message area gives feedback while saving and exporting and also displays errors. The console displays text output by the Arduino Software (IDE), including complete error messages and other information. The bottom righthand corner of the window displays the configured board and serial port. The toolbar buttons allow you to verify and upload programs, create, open, and save sketches, and open the serial monitor.

E. Proteus-ISIS Professional v7.7

Proteus software is used for simulation of the circuit diagram. Proteus is a Virtual System Modelling and circuit simulation application. The suite combines mixed mode SPICE circuit simulation, animated components and microprocessor models to facilitate cosimulation of complete microcontroller based designs. Proteus also has the ability to simulate the interaction between software running on a microcontroller and any analog or digital electronics connected to it. It simulates Input / Output ports, interrupts, timers, USARTs and all other peripherals present on each supported

processor. After simulating circuit in Proteus Software PCB design can be done directly.

IV. WORKING

The information is sent through a PC. The data is serially transmitted and received through 8051 controller. We are using AT89S51 microcontroller. The data is wirelessly transmitted through a zigbee dongle and received through another zigbee which is interfaced to the microcontroller. The message is displayed through a 16*2 LCD display.

V. CONCLUSION

Wireless operations permit services, such as long range communications, that are impossible or impractical to implement with the use of wires. It provides fast transfer of information and are cheaper to install and maintain. This paper provides an efficient way of displaying messages on Notice Board using Wireless Technology. It also provides user authentication in order to avoid any misuse of proposed system. The display boards are one of the major communications media for mass media. Also we realise that this project saves time, energy and hence environment. Cost of printing, photocopying is also reduced as information can be given to a large number of people from our ngertips. No need of any complex wires to display the message on lcd as it is wireless. It can be used in bus stations, railway stations, parks etc to display the messages wirelessly. This project can be used in colleges and other educational institutions. Thus we can conclude that this project is just a start, an idea to make use of radio frequency communication to a next level.

REFERENCES

- [1] Shuai Jiang, Dong Cao, Yuan Li, Member, and Fang Zheng Peng, "Grid-Connected Boost Half Bridge Photovoltaic Micro inverter System Using Repetitive Current Control and Maximum Power Point Tracking," Proceedings of the 33rd Annual Conference of the IEEE Industrial Electronics Society (IECON), , pp. 46-51, Nov. 2007.
- [2] E. Ferro and F. Potorti, "Bluetooth and Wi-Fi wireless protocols: a survey and a comparison", Wireless Communications, IEEE, vol. 12, no. 1, pp.12-26, February 2005.

[3] J. S. Lee and Y. C. Huang, "ITRI ZBnode: A ZigBee/IEEE 802.15.4 Plat-form for Wireless Sensor Networks", Proceedings of IEEE International Conference on Systems, Man, and Cybernetics, Taipei, Taiwan, vol. 2, pp. 1462-1467, October 2006

[4] Safaric, S.; Malaric, K, "Zigbee Wireless Standard ",IEEE International conference on Multimedia Processing and Communications, March 2006.