



COMPARATIVE STUDY OF VARIOUS PWM SWITCHING TECHNIQUES FOR VOLTAGE SOURCE INVERTERS

Shivaprasad B. Shetty¹, Rakshan Bhandary², Bommegowda K. B.³

^{1,2,3}Department of Electronics & Communication Engineering

N. M. A. M. Institute of Technology, Nitte, Udipi, India

shivaprasadshetty00@gmail.com¹, bhandaryrakshan@gmail.com², bgowda_kbl@nitte.edu.in³

Abstract

Different switching methods are used in power electronic circuits such as voltage source inverter. In this paper, the various types of PWM techniques for the control of voltage source inverters are studied and the best switching method is chosen from the conclusion drawn from the review. A highly efficient result can be obtained when the inverter uses a minimum number of components and can give out outputs that meet user requirements. In order to reduce the harmonic components in the output produced by VSI, a perfect switching method has to be used. Pulse Width Modulation (PWM) based switching power converters has advantages such as lower power dissipation, implementation and controlling is easier, has higher resistance to temperature variations and lastly its high compatibility with modern day digital microprocessors. Few of the widespread derivatives of PWM switching techniques used for control voltage are sinusoidal PWM and space vector PWM. These techniques are studied and compared in terms of parameters such as, how ideal the output is, the harmonic distortion, losses due to switching effects, and the mode in which they operate.

Keywords: Space vector PWM, Sinusoidal PWM, control of voltages, voltage source inverter.

I. INTRODUCTION

In olden days, generation of electrical power and the utilization of it was not complex. Now due to advancement in field of electronics, the networks have become more complex. [1].

Power control is one of the major issue, and day by day more efficient methods for control of electric power is being developed [2]. Previously, the control of electric power for the operation of equipment was either done manually or through electromechanical switches. With the advent of solid-state controllers and converters that are fast accurate and reliable, their use of increase has drastically increased [3]. One of the fastest and reliable methods used for switching in power electronics makes use of Pulse Width Modulation technique. PWM as a switching control has widespread applications in the field of electronics. PWM pulses are used in motor drivers, voltage source inverters and many other power electronics applications [4]. The voltage stored in batteries is in the form of DC voltage. For long distance transmission AC is preferred as it has minimal loss compared to DC. Most of the devices make use of AC power from an external source into DC power for the use of the device. While in comparison to DC, portability is an issue faced with AC power sources. The requirement can be fulfilled using batteries. Thus, for mobile AC power, inverters are needed. Inverters are known as DC to AC power converters [5]. They produce AC of a required amplitude and frequency from a DC source. The conversion is obtained by continuously turning on and off the switching devices namely IGBT, BJT and MOSFET's, or by forced commutated Thyristors depending on required output the switching devices are used. One of the most common problems in the power electronics industry is low-order harmonics, which cause distortions in voltage and current. One solution to reduce low-level harmonics in

high-power converters is to use PWM control techniques [6].

II. VOLTAGE SOURCE INVERTER

Conversion of DC voltage to AC voltage can be done with the help of a Voltage Source Inverter (VSI). A simple VSI consists of batteries which consists of cells connected in series and parallel combination. With the help of NPN and PNP transistors, the working of a VSI can be shown. They are connected in a push-pull manner in a common emitter configuration. To have a single control signal the bases and emitters of the transistors are shorted. Symmetrical bipolar DC supply is required for the two circuits. The positive DC supply is connected to collector of NPN transistor and negative supply to collector of PNP transistor, where magnitudes of both the polarities are equal. A resistive load is connected between the shorted points of the emitter and ground. The transistors work as amplifier and controlling sinusoidal voltage is applied across the transistor base and emitter. During positive half cycle of the input, the PNP transistor is off, and the load current flows through NPN transistor. Similarly, for negative half cycle of the input voltage, the PNP transistor conducts while the NPN transistor is off. A resistor of an appropriate value in series with the base will limit the current. And when the base signal magnitude is higher than the base to emitter conduction voltage drop, the base current is sinusoidal. Under the assumption of constant gain (h_{fe}) and the applied input is providing a voltage swing within the available voltage range, the output load current follows the input current.

The transistors in the Fig. 2 can carry current in a single direction (from collector to emitter) hence if the upper (NPN) transistor is on, the star (*) marked terminal of the load will get connected to the positive dc supply (+E), current enters this point, other load terminal being at ground potential. When NPN transistor turns off and PNP transistor turns on, the current flowing through the load changes in direction and polarity of the output voltage changes. By using resistive loads, we can maintain the instantaneous polarities between the voltage and current.

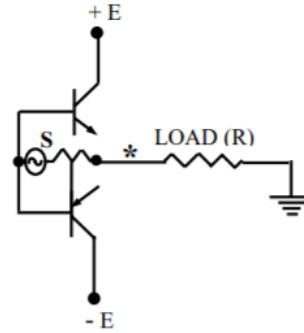

Fig. 1. Push-pull active amplifier circuit [7]

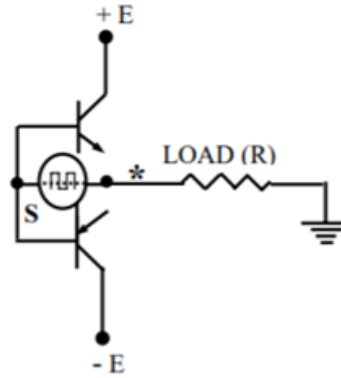

Fig. 2. Push-pull switched mode circuit [7]

The instantaneous current through a load and the instantaneous voltage across it may have different polarity. The polarity of the voltage and current can be fixed with the help of inverter switching pattern. Hence irrespective of the load, phase of the voltage magnitude and frequency remains constant. Therefore, in the fig. 2 the current can flow in both directions in the switches as well as can be controlled for a non-resistive load. A bidirectional current can flow in fig. 3, if an anti-parallel diode is connected across each transistor switch. The combination of anti-parallel diode and transistor acts as a switch. The push pull operation can be analyzed using bidirectional current carrying switches. The modified circuit is shown in Fig. 4. A bi directional current switch can be obtained by connecting an anti-parallel diode across a IGBT and a BJT. But for a faster and higher voltage and current specifications IGBT switches are used. And they are easier to use compared to other switches [7].

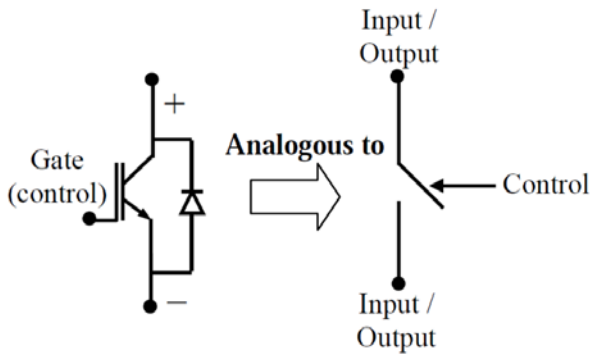

Fig. 3. Bi-directional controlled switch [7]

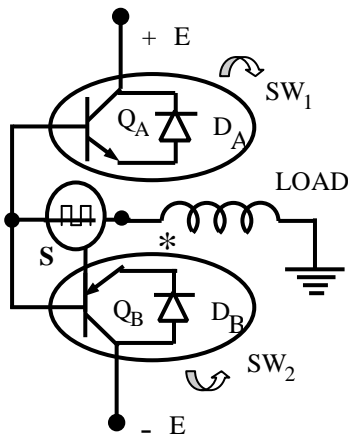

Fig. 4. Modified push-pull circuit [7]

Using the above methods, a full bridge inverter can be built. The full bridge inverter consists of four switches, two in each leg as shown in Fig. 5. This work as follows, when the switches S_1 and S_2 are closed simultaneously, the input voltage V_{dc} can be seen across the load and current flows from the point a to b. And when the switches S_3 and S_4 are turned on simultaneously the voltage across the load is reversed and the current through the load flows from b to a [8].

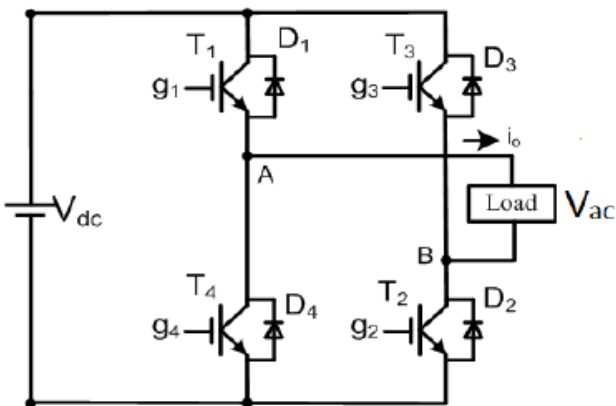

Fig. 5. Full bridge Inverter [9]

III. COMPARATIVE STUDY OF MODULATION TECHNIQUES

In this section, we will be presenting a qualitative analysis of the different PWM switching techniques used in the voltage source inverters. The comparison has been made considering reference and carrier signals.

A. Sinusoidal PWM

Sinusoidal PWM is the technique used for the generation of PWM outputs with a Sinusoidal signal as modulating signal. The sine wave is compared with a high-frequency triangular wave (as a carrier wave) which determines the ON/OFF condition of the PWM signal. The frequency of the output voltage is determined by the given modulating signal. By changing modulation index the rms value of output PMW wave can be altered. When compared to different multiphase techniques, the distortion factor is improved [11]. The production of switching signals by sinusoidal PWM is shown in Fig. 6.

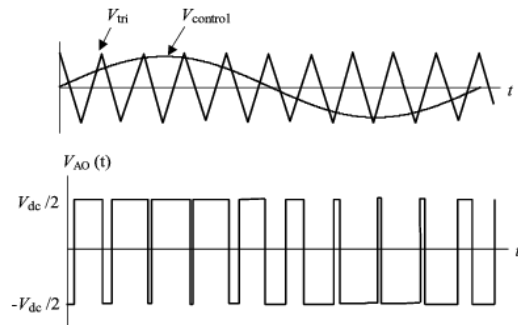

Fig. 6. Sinusoidal PWM waveform [22]

B. Single-Pulse Width Modulation

In this type of modulation, the rectangular is taken as reference signal and is compared with a triangular carrier wave which results in the generation of PWM signal.

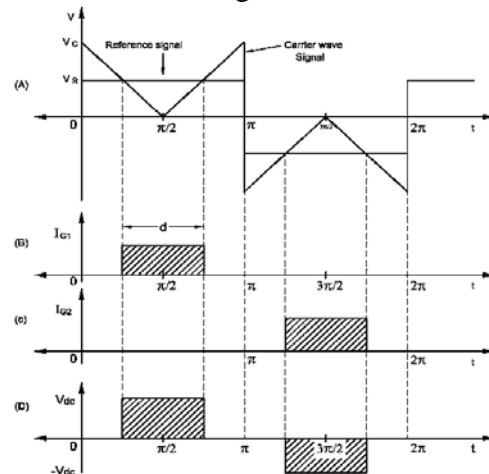

Fig. 7. Single-Pulse PWM waveform [20]

Single pulse is present per half cycle of the output voltage in Single-PWM. The pulse width of output signal can be varied by altering the amplitude of rectangular wave. The production of switching signals by a single PWM is shown in Fig. 7. The reference signal frequency gives the fundamental frequency of the output [9].

C. Multi-Pulse Width Modulation

In Multiple-pulse width modulation, the output signal generated has multiple pulses per half cycle of the reference signal. The production of switching signals by multi PWM is shown in Fig. 8. Carrier signal amplitude is varied to alter the width of each pulse. Triangular carrier wave frequency used is greater when compared to that of Single-pulse width modulation technique. Number of pulses in the output is dependent on the frequency of carrier. By the use of several pulses in per half cycle reduces harmonic content of an output voltage. Of The pulses in the output signal is obtained by comparing the triangular signal with reference rectangular signal. The output voltage is controlled by changing the modulation index [9].

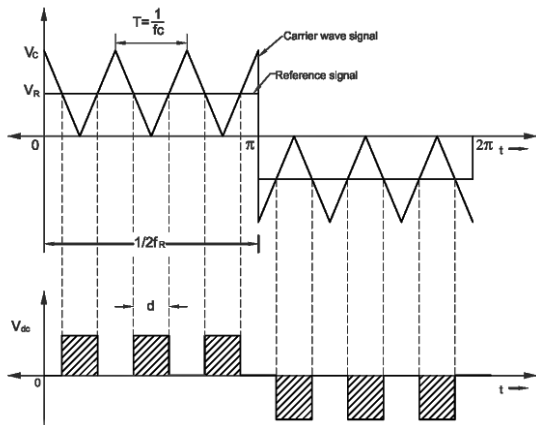

Fig. 8. Multi-Pulse PWM waveform [20]

D. Hysteresis Band Pulse Width Modulation

Hysteresis pulse width modulation is the technique in which freely oscillates within a predefined error band that is known as "hysteresis band". The switching of output takes place at vertices of the triangular wave. By varying frequency of the modulating signal, the number of pulse and pulse width can be adjusted. The fundamental output voltage is dependent on the reference voltage. Hence, switching losses can be greater in this technique compared to other techniques [9]. The generation of switching signals by Hysteresis PWM is shown in Fig. 9.

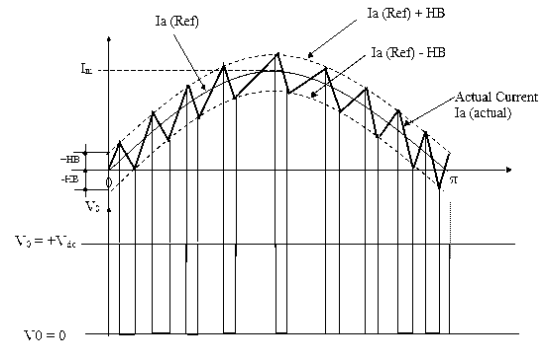

Fig. 9. Hysteresis band PWM [21]

E. Trapezoidal modulation

In this type of modulation, the triangular high-frequency carrier is compared with the trapezoidal reference the switching instance is generated. The generation of switching signals by Trapezoidal modulation is shown in Fig. 10. Peak fundamental output voltage is increased in this modulation techniques but the output contains lower order harmonics [12].

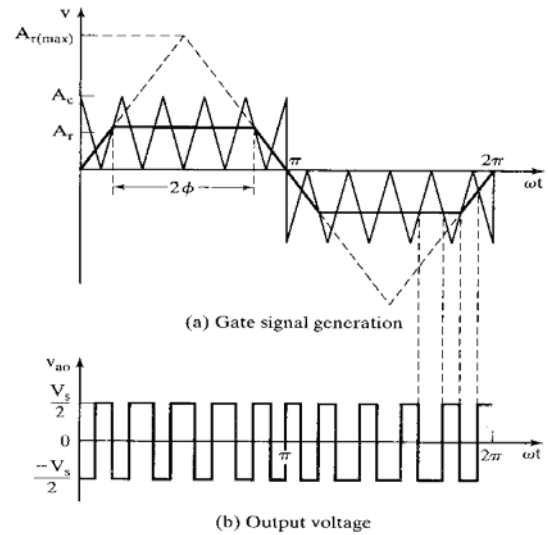

Fig. 10. Trapezoidal modulation [12]

F. Staircase Modulation

In staircase PWM technique, the modulated wave eliminates specific harmonics. The desired quality of output is obtained by choosing the number of steps of the modulation frequency ratio staircase wave. For a half cycle if the number of pulses is less than 15 than this is optimized pulse width modulation [12]. The generation of switching signals by staircase modulation is shown in Fig. 11.

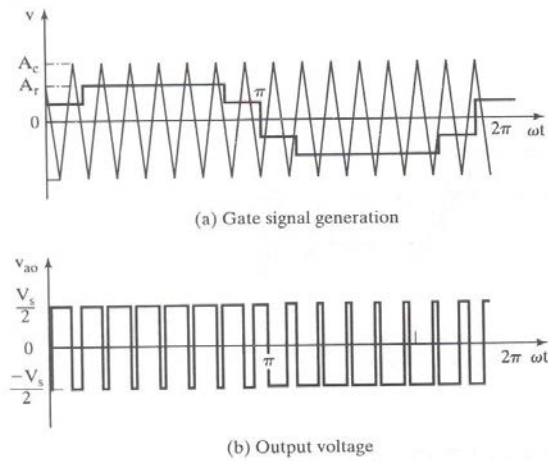

Fig. 11. Staircase Modulation [12]

G. Stepped Modulation

In this modulation, the signal is stepped wave. This wave is divided into specific interval in order to eliminate specific harmonics and to control the magnitude of the fundamental component and, with each interval being controlled individually. The distortion present in this technique is low when compared to normal PWM but it has higher fundamental amplitude [12]. The generation of switching signals by stepped modulation is shown in Fig. 12.

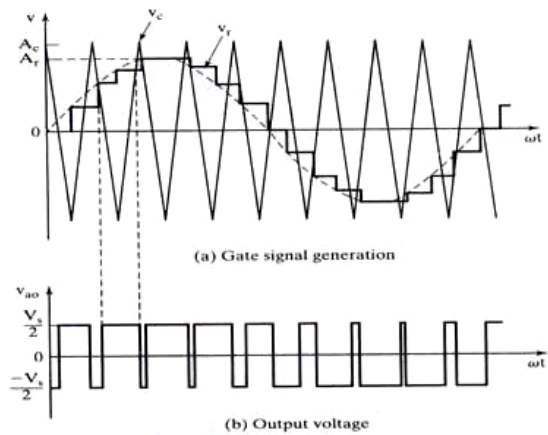

Fig. 12. Stepped modulation [12]

H. Harmonic Injected Modulation

The modulation signal in this type of modulation sinusoidal signal is injected with harmonics and is compared with the high-frequency triangular carrier wave. The generation of switching signals by harmonic injected modulation is shown in Fig. 13. The resulting modulating signal is a flat-topped waveform and it minimizes the amount of overmodulation. An output voltage of low distortion and higher fundamental amplitude are provided. When compared to normal sinusoidal PWM techniques the amplitude of fundamental components is approximately 15%. [12].

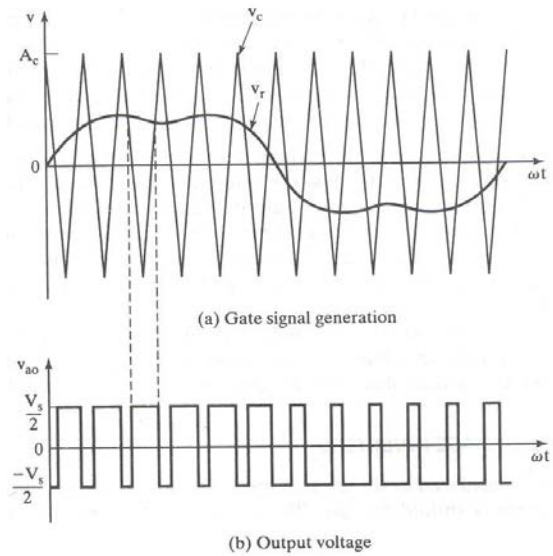

Fig. 13. Harmonic Injected Modulation [12]

H. Multicarrier PWM techniques

1. Phase Disposition (PD) PWM

In Phase disposition, ‘n’ levels are present at the output and (n-1) triangular carrier waves are in phase. The carrier wave is compared with the modulating signal to produce a PWM output [13, 14, 17].

Table 1. Comparison of different PWM techniques

Ref. No.	PWM Technique	Reference Signal	Carrier Signal
[22]	Sinusoidal PWM	Sinusoidal	Triangular
[20]	Single-Pulse Width Modulation	Rectangular	Triangular
[20]	Multi-Pulse Width Modulation	Rectangular	Triangular

[21]	Hysteresis Band PWM	Triangular	-
[12]	Trapezoidal Modulation	Trapezoidal	Triangular
[12]	Staircase Modulation	Staircase	Triangular
[12]	Stepped Modulation	Step	Triangular
[12]	Harmonic Injected Modulation	Sine Wave with injected Harmonics	Triangular
[10]	Multicarrier PWM	Sinusoidal	Triangular

2. Phase Opposition Disposition (POD) PWM

In POD, for n levels of output (n-1) triangular carrier place one above the other and they have 180° difference between them [13, 14, 17].

3. Alternative Phase Opposition Disposition (APOD) PWM

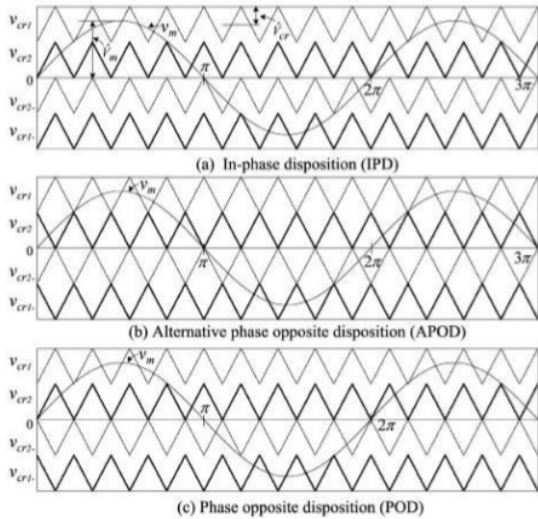

Fig. 14. Multicarrier PWM (PD, POD, APOD) [10]

I. Space Vector PWM

This modulation scheme is fast, advanced reliable and efficient PWM technique when compared to others. This method is used to generate 3 phase PWM signals. Vector PWM technique is a vector approach to PWM for three-phase inverters. This method is used in the vector-controlled application. This technique takes high computing power but produces fewer harmonics. This type of PWM is more efficient [16, 17, 18]. The topology of a three-stage voltage source converter is shown in Fig.15.

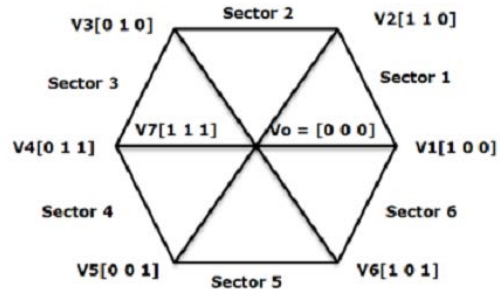

Fig. 15. Space Vector Modulation [18]

CONCLUSION

Modulation techniques such as Sinusoidal PWM Single PWM, Multi-Pulse Width Modulation, Hysteresis Band PWM, Harmonic Injected Modulation, Stepped Modulation, Staircase Modulation, Multicarrier PWM techniques are discussed. Space Vector PWM is one of the advanced switching techniques used in the voltage source inverters. This study gives a comparative study on various types of modulation techniques which are implemented or can be implemented in voltage source inverters.

REFERENCES

- [1] Bimal K. Bose, "Modern Power Electronics and AC Drives", Pearson Education, 2003.
- [2] Muhammad H. Rashid, "Power Electronics, Circuits, Drives and applications", Pearson Education Inc. 2004.
- [3] Vas P., "Electrical Machines and Drives a Space-Vector Theory Approach", Oxford University Press, 1992.
- [4] R. Kameswara Rao, P.Srinivas, M.V. Suresh Kumar, "Design and analysis of various inverters using different PWM techniques", The International Journal of Engineering and Science (IJES), pp 41-51, 2014.
- [5] N. Mohan, T. M. Undeland, "Power Electronics Converters, Applications and

- Design”, 3rd edition, John Wiley & Sons, New York, 2003.
- [6] Hardik Shahane, Shekhar Onkarkar, Prashik Khandekar, Zalendra Bhagat, Resham Tondare, “Review of Different PWM Techniques”, Vol. 4, Issue 3, March 2018.
- [7] Introduction to Voltage Source Inverter, Version 2 (NPTEL EE) IIT Kharagpur.
- [8] Subhitcha R., V. Sowmya, R. Seyezhai, “Performance Analysis of PWM based Voltage Source Inverter”, International Journal of Advanced Research in Basic Engineering Sciences and Technology (IJARBEST), Vol. 3, Issue 7, July 2017.
- [9] Hassan M Abdar, A Chakravarthy, D.H. Moore, Jordan Murray, “Design and implementation a specific grid-tie inverter for an agent-based microgrid”, IEEE Energytech, 2012.
- [10] Tanuj Dabas, Ram Avtar, “THD Analysis of Cascaded H-Bridge with Level Shifted Multicarrier Modulation”, Advances in Computer Science and Information Technology (ACSIT), Vol. 2, 2015.
- [11] Zhenyu Yu, Arefeen Mohammed, Issa Panahi, “A Review of Three PWM Techniques”, American Control Conference, June 1997.
- [12] Satish Kumar Peddapelli, “Recent Advances in Pulse Width Modulation Techniques and Multilevel Inverters”, World Academy of Science, Engineering and Technology International Journal of Electrical and Computer Engineering, Vol. 8, 2014.
- [13] Dmitry Baimel, Saad Tapuchi, Nina Baimel, “A Review of Carrier-Based PWM Techniques for Multilevel Inverters' Control”, WSEAS Transactions on Power Systems, Vol. 12, 2017.
- [14] Bhavana Radadiya, Meeta Mantani, Tapankumar Trivedi “Analysis and Comparison of PD, POD, APOD PWM Techniques for Symmetrical Multilevel Inverter”, International Journal of Advanced Engineering and Research Development Vol. 4, Issue 4, April -2017.
- [15] Komal Shinde, “Five Level Cascaded H-Bridge Multilevel Inverter using Pulse Width Modulation, In-Phase and Alternate Phase Opposition Deposition Techniques”, IJEDR, Vol. 6, Issue 2, 2018
- [16] Manish Sahajwani, Sushma Patel, “Review on Modern Pulse Width Modulation Techniques Based Inverters”, International Journal of Advanced Research in Electrical, Electronics and Instrumentation Engineering, Vol. 5, Issue 9, September 2016.
- [17] Omer Turksoy, Unal Yılmaz, Adnan Tan, Ahmet Teke, “Comparison Study of Sinusoidal PWM and Space Vector PWM Techniques for Voltage Source Inverter”, Natural and Engineering Sciences, 2017,
- [18] Nishant Kumar Yadav, Dharmendra Kumar Singh, “A Review on Stability Enhancement in Power System using Space Vector Modulation Controlled STATCOM”, International Journal of Science, Engineering and Technology, Vol. 5, Issue 2, 2017.
- [19] Electrical Revolution [http://www.myelectrical2015.com/2017/07/pulse width modulation of an inverter.](http://www.myelectrical2015.com/2017/07/pulse-width-modulation-of-an-inverter)
- [20] Universal Unified Power Converter for Micro-hydropower - Scientific Figure on Research Gate. [https://www.researchgate.net/figure/Hysteresis-band-PWM control.](https://www.researchgate.net/figure/Hysteresis-band-PWM-control)
- [21] Nalin K. Mohanty, Ranganath Muthu, “Implementation of DSP Based Cost Effective Inverter Fed Induction Motor Drive with VisSim”, Journal of Electrical Engineering, Vol. 63, pp. 115-119, 2012.