



DIRECTION OF ARRIVAL ESTIMATION USING A PROPAGATOR METHOD FOR STATIC SCENARIO

¹D. D. Khumane ²S. M. Jagade ³V.M. Mhalgi

¹Research Scholar, National Institute of Electronics & Information Technology, Aurangabad, India.

²Department of Electronics and Telecommunication Engineering, S.T.B. College of Engineering, Tuljapur, India

³Department of Computer Science and Engineering, S.T.B. College of Engineering, Tuljapur, India

¹dkhumane@gmail.com, ²smjagade@gmail.com, ³vijay.mhalgi@gmail.com

Abstract

This paper presents analysis of simulation results for Direction of arrival estimation for smart antenna system using non Eigen value decomposition based algorithm. Direction of arrival (DOA) estimation in smart antenna for identifying the directions of the desired signals and the null steering beamformer to adapts the antenna pattern to steer the main beam towards the desired user and nullify all other interference. Once DOA estimation is over using beamforming algorithm beam form in desired direction using any one beamforming algorithm. This system can be used to reduce multipath and co-channel interference. This paper simulation results showing performance of power spectra for DOA estimation using PM appear for smart antenna system. These benefits include the enhancement of coverage and the channel capacity , lower transmitted power, better signal quality, higher data rate and providing value-added services such as user's position location (PL) and at the same time to minimize interference arising from other user by introducing nulls in their direction.

Index Terms: Direction- of-Arrival (DOA) Estimation, Least Mean Square (LMS), Multiple Signal classification (MUSIC), Propagator Method (PM), Position Location (PL).

I. INTRODUCTION

There is an ever increasing demand on mobile wireless operators to provide voice and high speed data services. At the same time, these operators want to support more users per base station to reduce overall network cost and

make the services affordable to subscribers. As a result, wireless systems that enable higher data rates and higher capabilities are pressing need. Unfortunately because the available broadcast spectrum is limited, attempts to increase traffic within a fixed bandwidth create more interference in the system and degrade the signal quality. When omni-directional antennas are used at the base station, the transmission and reception of each users signal becomes a source of interference to other users located in the same cell, making the overall system interference limited.

The demand for wireless services has risen dramatically from few years. Wireless communication systems are evolving from the second generation systems to the third and fourth generation systems, which will provide high data rate multimedia services as video transmission. New value added services such as the position location (PL) services for emerging calls, the fraud detection, intelligent transportation systems, and so fourth are also coming in to reality[1,2,3].

The smart antenna systems can generally be classified as either switched beam or adaptive array systems. In a switched beam systems can generally be classified as either switched beam or adaptive array systems. Fig. 1 illustrates the relative coverage area for conventional sectorized, switched beam and adaptive antenna systems. Both types of smart antenna systems provide significant gains over conventional sectorized system. The low level of interference on the left represents a new wireless system with lower penetration levels. The significant level of interference on the right represents either a wireless system with more users or one

using more aggressive frequency re-use patterns. In this scenario, the interference rejection capability of the adaptive system provides significantly more coverage than either the conventional or switched beam systems. Another significant advantage of the adaptive antenna systems is the ability to “create” spectrum.

Because of the accurate tracking and robust interference rejection capabilities, multiple users can share the same conventional channel within the same cell. System capacity increases through lower inter-cell frequency re-use patterns as well as intra-cell frequency re-use.

The ability to continuously change the beam pattern with respect to both lobes and nulls separates the adaptive approach from the switched type. As interfering signals move throughout the sector, the switched beam pattern is not altered because it only responds to movements in the signal of interest. In fact, when an interfering signal begins to approach the signal of interest and enters the gain of the main lobe, the interfering signal will be processed identically to the desired signal and signal to interference ratio will degrade accordingly. In contrast, the adaptive system is able to continue to distinguish between the signal and the interferer and allow them to get substantially closer than in the switched beam system while maintaining enhanced signal to interference ratio levels. The most sophisticated adaptive smart antenna systems will hand-over any two co-channel users, whether they are inter-cell or intra-cell, before they get too close and begin to interfere with each other.

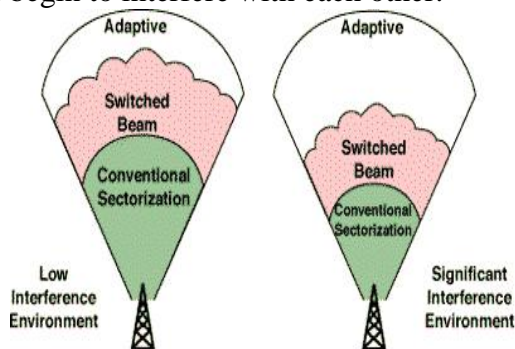

Figure. 1. Coverage patterns for switched beam and adaptive array antennas

The adaptation achieved by multiplying the incoming signal with complex weights and then summing them together to obtain the desired radiation pattern. These weights are computed adaptively to adapt to the changes in the signal

environment. The complex weight computation based on different criteria and incorporated in the signal processor in the form of software algorithms like Least Mean Square. [6]

A smart antenna technology can achieve a number benefits like increase the system capacity, greatly reduce interference, increase power efficiency [4, 5]. In the following section we review on the smart antenna technology with the help of simulation by using MATLAB

II. BASICS OF DOA ESTIMATION

Since most RF antennas amplifiers, mixers, filters and ADC technologies have reached a mature state, accurate estimation of the angle of arrival of signals impinging an array of antennas becomes the most important parameter regarding the performance of an adaptive array. Assuming a linear and isotropic transmission medium, multiple impinging wave fronts can be modeled as the superposition of these wave fronts impinging on the array. It is therefore necessary for the DOA estimation algorithm to be able to resolve impinging and often fully coherent wave fronts into their respective DOA's. Many DOA estimation algorithms exist, but only a few have found use in smart antennas i.e. conventional methods, linear prediction methods, eigenstructure methods and estimation of signal parameters via Rotational invariance techniques (ESPRIT) [6]. All these methods are based on the digital beamforming (DBF) antenna array. Signals received by individual antenna elements, are down converted to base band signal then they are digitized and fed into a digital signal processing (DSP) chip where the DOA estimation algorithm is executed. In this paper we take a brief review and compare the performance analysis of MUSIC and PM algorithm. Here MUSIC algorithm is based on eigenvalue decomposition and PM is non eigenvalue decomposition based DOA estimation algorithm. Eigenvalue decomposition based algorithm require lot of calculation for finding received data covariance matrix where as non eigenvalue decomposition based algorithm requires competitively less calculation for finding DOA of desired users. Once DOA is estimated then forming beam towards the desired users PL using any one beamforming algorithm like LMS algorithm, RLMS algorithm optimal beamforming algorithm et.al.

But in this paper comparative study of simulation results of Music algorithm is done on the basis of number of incoming signal and respective signal power signal power spectra by considering some fix values of other parameter like signal to noise ratio, No of incoming signals, Array spacing, No Iteration or snapshot et.al.

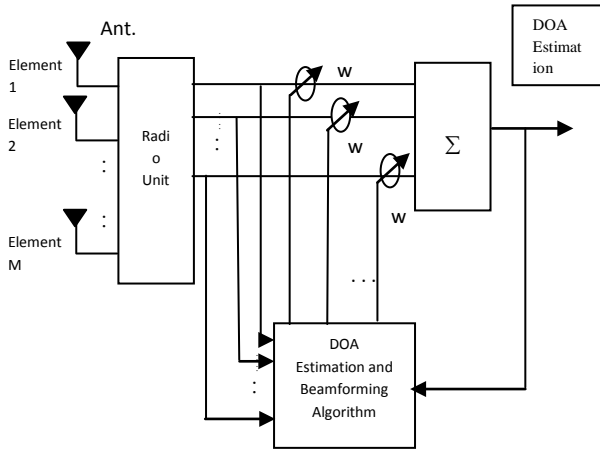

Figure. 2 Proposed Model for DOA estimation and beamforming [9]

And for direction of arrival estimation (DOA) and beamforming would like to simulate DOA Estimator and beamformer as follows fig.2. This method may be creates the radiation pattern of the antenna array in the desired direction and by nulling the pattern in the unwanted directions. This method in theory should minimize the signal to interference ratio.

III. SIMULATION STUDY & RESULTS

The simulation is developed in MATLAB the following parameters are used for the DOA estimation. First set the noise properties SNR=10dB antenna properties, M=6 number of elements in antenna array, N=100 number of snapshot. Then set the incoming signal properties, L=5 number of incoming signals, $f_0 = 1 \times 10^9$ incoming signal frequency and varying the (d) array spacing and trying to detect at how much array spacing result is better , Fig. 4. Shows the power spectrum versus the azimuth angle for the six coherent sources with DOA that are at some degree apart it is assumed that six coherent signals are received with azimuth DOA at 40° 50° 55° 60° and 70° and a SNR of 10dB for all sources. , and the unknown noise is in complex symmetric form.

$$X(t) = A(\theta) * s(t) + n(t) \quad (1)$$

Where A=steering vector, s=signal received at first antenna. Then initialization of covariance matrix Rxx, then the PM spectrum are shown in Fig. 3, these spectrums are randomly taken.

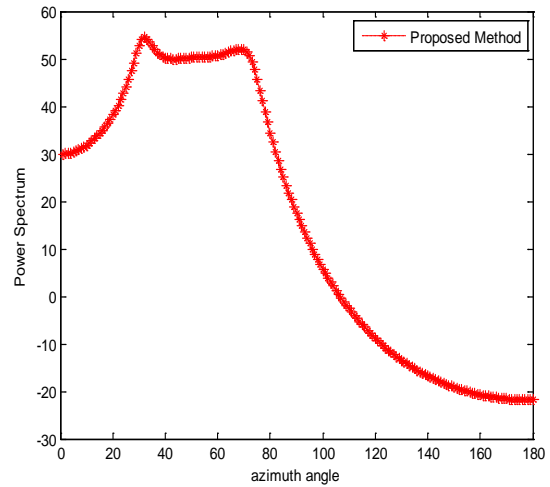

Figure.3. Simulation result when d=0.2M

For above Result Different parameters are Elevation angles are 40° 50° 55° 60° 70° , M=6, N=100, SNR=10dB and d=0.2M

For below Result Different parameters are Elevation angles are 40° 50° 55° 60° 70° , M=6, N=100, SNR=10dB, d=0.3M

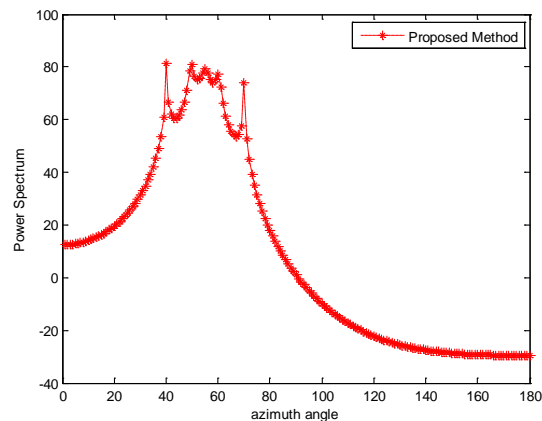

Figure.4 Simulation result when d=0.3M

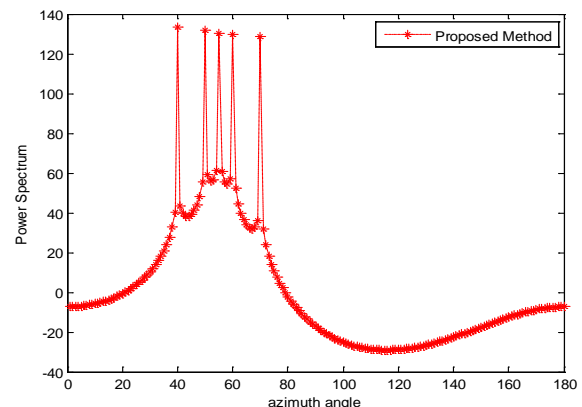

Figure.5. Simulation result when d=0.5M

For above Result Different parameters are Elevation angles are 40° 50° 55° 60° 70° , $M=6$, $N=100$, $SNR=10dB$ and $d=0.5M$

For below Result Different parameters are Elevation angles are 40° 50° 55° 60° 70° , $M=6$, $N=100$, and $SNR=10dB$, $d=0.7M$

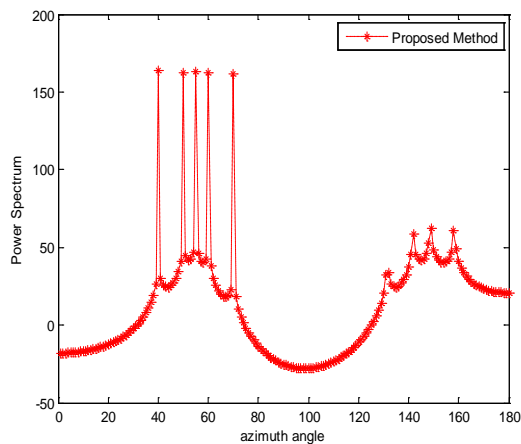

Figure.6.Simulation result when $d=0.7M$

It becomes clear that the proposed algorithm gives accurate DOA with maximum amplitude of power spectrum at

Above result derived by varying array spacing $0.2 M$ to $0.7 M$ finally we conclude that result derived with $d=0.5 M$ is better sharper to desire angle and with minimum distortion at other angles are low competitive to other result

In above result all incoming signals DOA (Azimuth angle) are accurately estimated in proposed algorithm. But DOA estimated by MUSIC algorithms is not accurate and it fails to estimate all six incoming signals DOA.

IV. CONCLUSION

Here the simulation result shows that when elevation angles are 1° or 2° apart then resultant is crowded in nature but when 3° degrees apart then simulation result are clearly shown .when angle are available as floating value (i.e. 50.5°) then simulation result is improperly or crowdedly shown by proposed method. But when comparing performance of PM & MUSIC, Proposed method will estimating all 6 azimuth angle accurately. But MUSIC algorithm estimating 3 DOA (azimuth) angle with some deviations and completely fails for other two signals . When all incoming signals are 20° to 30° apart then MUSIC algorithm estimate all DOA of incoming signals with small deviation in its angle. One more think is

observed that amplitude of power spectra of PM higher than MUSIC.

Hence performance of PM algorithm is better than the MUSIC algorithm for multiple signals Direction of Arrival Estimation

REFERENCES

- [1] T.S. Rappaport, J.H. Reed and B.D. Woerner, "Position location using wireless communications on highways of the future," *IEEE Communication Magazine*, vol. 34, no.10, pp. 33- 41, 1996.
- [2] G.V. Tsoulos, "Smart antennas for mobile communication systems: benefits and challenges,"*IEEE Electronic & Communication Engineering Journal*, Vol 11, no.2 pp. 84-94, 1999.
- [3] K.J. Krizman, T.E. Biedka, and T.S. Rappaport, "Wireless position location: fundamentals, implementation strategies, and sources of error," in *Proc. IEEE Vehicular Technology Conference*, Vol 2 pp.919-923, Phoenix, Ariz, USA, May 1997.
- [4] Tsoulos G.V. Meach MA. Swalas S.C. "Adaptive Antennas for Third Generation DS-CDMA Cellular Systems", *Proceedings of the 45th Vehicular Technology Conference*, Vol 1, pp. 45-49, July 1995.
- [5] Okamoto G.T. "Smart Antennas and Wireless LANS." *Kluwer Academic Publishers*, Norwell Mass., 2002
- [6] Godara, L.C., "Application of Antenna Arrays to Mobile Communications, Part II: Beamforming and Direction-of Arrival Considerations," *Proceedings of the IEEE*, Vol. 85, No. 8 pp 1195- 1245, August 1997.
- [7] Ch. Santhi Rani, P.V. Subbaiah, K. Chennakesava and S. Sudha Rani, "LMS and RLS Algorithms for Smart Antennas in a W-CDMA Mobile Communication Environment," *ARPN Journal of Engineering and Applied Sciences*" vol. 4, no.6, August 2009.
- [8] Nizar Tayem and Hyuck M. Kwon, "L-Shape 2-Dimensional Arrival Angle Estimation with Propagator Method", *IEEE Trans. On Antennas and Propagatio.*, Vol. 53, No. 5, May 2005