



# AN ISOLATED BIDIRECTIONAL EQUALIZER FOR EV BATTERY

Keerthi N S<sup>1</sup>, Priya S<sup>2</sup>

<sup>1,2</sup>Electrical and Electronics Engineering Department, NSS College of Engineering Palakkad, Kerala, India

[keerthins95@gmail.com](mailto:keerthins95@gmail.com)<sup>1</sup>, [Priyasyamtech@gmail.com](mailto:Priyasyamtech@gmail.com)<sup>2</sup>

## Abstract

**Every unbalanced battery will reduce the life of a battery pack and therefore equalization of batteries is performed in-order to protect them from damage, explosion and poor battery utilization. Several converter equalization circuits are used in-order to achieve fast equalization. This paper presents an isolated bidirectional equalizer with centralized topology which are used in equalization circuits of two series connected lithium-ion batteries.**

**Keywords: Battery equalizer, Charge equalization, Bi-directional DC-DC converter, Lithium-ion cell**

## I. INTRODUCTION

The decreasing fuel energy, increasing oil cost and pollution had led the researchers to think about an alternative to fuel energy and it is nothing but renewable source of energy. Renewable energy sources like solar energy, wind energy, tidal energy has an immense influence on many applications related to electric vehicle. One of the most interested area of research for electrical engineers are electric vehicles, in which the main focus is on its batteries. Batteries of electric vehicle suffer from a lot of issues like complications of charging, equalization, life of batteries, and the lack of charging infrastructure. Also, battery chargers can produce destructive harmonic effects on electric utility distribution systems although chargers with an active rectifier front end can mitigate this impact. Battery performance depends on charging levels and charging infrastructure. There are mainly three charging levels for any electric vehicle battery. The structure of EV battery can be on-board or

off-board with unidirectional or bidirectional power flow [1].

Battery performance not only depends upon types and charging characteristics of batteries but also on charging equalization. Repeated charging and discharging of battery cells result in voltage imbalance among the cells. It is very important to have a battery with its maximum efficiency to work for, so if any unbalance occurs in the battery pack which has a number of cells connected in series or parallel may lead to failure or explosion of batteries. There have been many efforts taken to find and develop a battery pack for EV which has good performance and high storage capacity. Ideally, a battery pack with no difference found among their cells are considered to be stronger and high capacity. In practical case charge imbalance occur due to internal resistance, ambient temperature during charging and discharging and degradation. Therefore, voltage monitoring and balancing is to be done for each cell to prevent any single cell from experiencing over or under voltage problem. Equalization improves the battery performance, life of the battery and efficiency, thereby reducing some of the issues of EV batteries. Equalization can be of dissipative or non-dissipative type. High energy consumption and low efficiency is the result of dissipative type of equalization therefore most of the researchers are focusing on non-dissipative type of equalization [2].

A large number of charge-equalization technologies with DC-DC topologies are now trending in application due to their high equalization accuracy and efficiency. According to the structure they can be divide into two centralized and distributed structure. In distributed structure, every single cell has its

own converter circuit making it bulky and as the number of cells increases the volume of the entire structure increases making it quite complex [3]-[4]. Therefore, we move on to centralized structure with one common equalization circuit to control all the cells making it more reliable and simpler to work on. The cell which is to be equalized is connected with the converter circuit through the cell selection block. Equalization strategy often look for battery voltage. The equalization is initiated when the battery is inconsistent and when the battery voltage is equal equalization stops. And if early termination of charging or discharging cycle leads to reduced capacity and life of battery. Therefore, monitoring cells in real time and maintaining the cell voltage is essential. Various Battery Management Systems are popular in nowadays but they still have some problems with cell equalization. Large dissipation of heat energy is suffered in most common method of resistive current shunt. Certain methods of cell balancing use energy storage element capacitor to transfer excess energy from high voltage cell to low voltage cell. But they possess some imperfect balancing due to the voltage drop across the switches [5]-[6].

The charge equalization system having a centralized structure which deals with a bidirectional full-bridge converter is presented in [7]. Lithium-ion phosphate battery pack was used for the experiment. Even though it constitutes bidirectional power flow the complexity of the circuit is more since it consists of large number of switches and thus requirement of driver circuits is more which reduces stability of the converter. This bidirectional full bridge topology is also used in [8] and the work is centered on equalization algorithm to reduce time and energy loss during equalization. It must focus on the variations that happens in the state of charge of the cell. The energy flow between the cell and the battery string is contributed by a flyback converter in [9] and [10]. In [9] they had mainly focused on size reduction and smooth balanced operation. However, the number of bidirectional switches and polarity switches is much high and the issue of voltage spike caused by leakage inductance is not completely avoided. A battery charge equalization algorithm for lithium-ion batteries for EV application is discussed in [10]. They

reduce the risk of explosion and improves the battery life. The number of bidirectional and polarity switches also increases with increased number of cells.

The paper presents a battery charger which supports the centralized charge equalization with a bidirectional DC-DC converter to exchange energy between cell and the battery string. The number of bidirectional and polarity switches for the system is much less thereby reducing the complexity of the electrical circuitry. Moreover, it improves equalization efficiency, reduces switching losses and eliminates voltage spike. The rest of the paper is organized as follows. Section II deals with the overview of bidirectional charge equalizer. Design parameters are discussed in section III and simulation results are presented in section IV. Concluding remarks are given in section V.

## II. OVERVIEW OF BIDIRECTIONAL CHARGE EQUALIZER

### A. Circuit Description

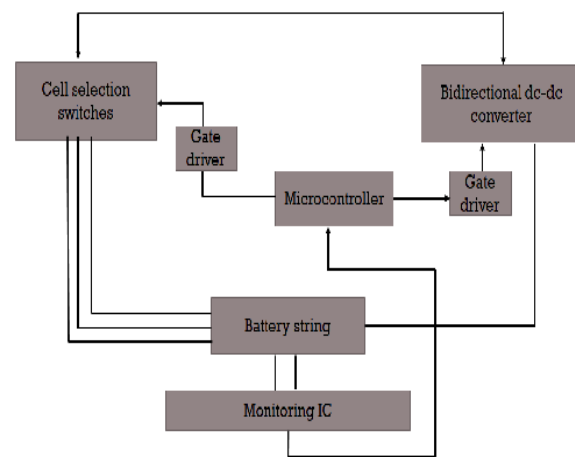

Fig. 1. Block diagram of a charge equalizer

Block diagram of the presented charge equalization system is shown in fig. 1. A bidirectional DC-DC converter is used in the system which allows the transfer of excess energy from the selected cell to the battery string. Battery string is directly connected to the output side of the converter circuit. The input of the circuit is connected to the cell that is to be equalized. The selection of the required cell with unbalance voltage is controlled by the cell selection switches. According to the boost and buck mode of the converter the overcharged and undercharged cell come into action. All the cells

of the battery string are regularly monitored by the monitoring IC and it gives command to the microcontroller. The microcontroller thus decides the cell to be selected and it gives the required pulse to turn on the switch through a gate driver. The microcontroller also provides the gate signals to the converter switches and thus it operates in the desired mode. A battery string consists of a large number of cells, it is necessary to equalize all the belonging cells but here we are presenting a prototype with only two cells in the battery string. We can apply this system to any number of cells as per our requirement and application.

This system uses a centralized topology which reduces the number of converter circuits and here we only require one common converter circuit. Switches Q5, Q6, and Q7 represents the cell selection switches and Q1 to Q4 represents the polarity switches for connecting the unbalanced cells to the converter circuit. When a single cell is undercharged the equalization is activated by selecting the cell and connecting to the bidirectional converter. Converter operates in boost mode and transfers the extra energy to the battery string. When any cell is found to be undercharged, equalization is activated and the converter is operated in buck mode and allows the undercharged cell to be charged from the battery string.

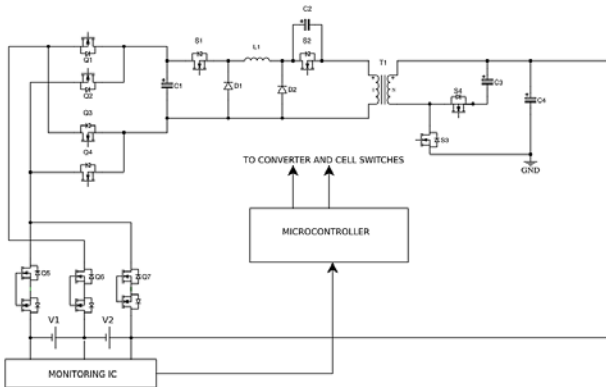

Fig. 2. Schematic diagram of charge equalizer

**B. Bidirectional DC-DC Converter**

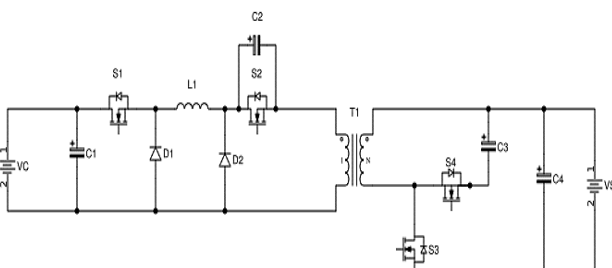

Fig. 3. Bidirectional converter circuit

The bidirectional DC-DC converter shown in the figure consists of four switches and a high frequency transformer. The turns ratio of the transformer is 1: *n*. The low voltage side of the transformer is connected to the single lithium-ion cell which is to be equalized. The input side consists of two switches S1 and S2. High voltage side of the transformer is connected to the entire battery string.

During the boost mode, the extra energy is transferred from overcharged cell to the battery string. The duty cycles of switches are given in fig. 4. Switch S3 is always turned off during the boost mode.

The equalization is activated when an undercharged cell is monitored and the converter needs to operate in buck mode during this condition. The respective gate pulses for the switches are given in the waveform.

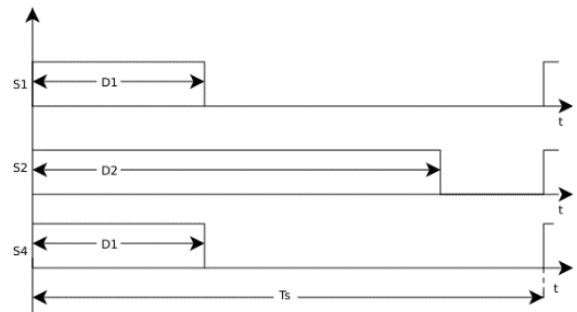

Fig. 4. Duty cycle in boost mode

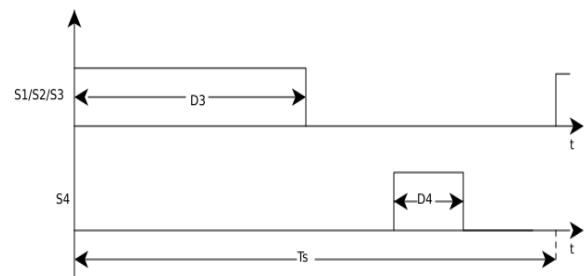

Fig. 5. Duty cycle in buck mode

**C. Characteristics of Lithium-ion Battery**

One of the major energy sources of electric vehicles is lithium ion cells. A complete battery pack consists of many cells connected in series and parallel to drive an electric vehicle. When they are connected in series for a particular application, then their cell voltage is an important factor. They cannot withstand the

overtoltage so the control of cell voltage and equalizing the voltage is very important for the smooth functioning of the battery. Over discharge leads to reduced life-cycle of the battery and over charging may lead to high explosion [12]. The one who is operating with the battery needs to know the complete knowledge about its characteristics and working. Lack of information leads to degradation of cell's life. Therefore, it is necessary to monitor the cell voltage and to estimate the state of charge. Lithium ion battery is widely used since it is capable of achieving high energy density, higher cell voltage, better life cycle and easy maintenances. Certain safety measures should be taken to the cells. One of the main problems with the development of these batteries is nothing but its cost.

### III. DESIGN PARAMETERS

Rated voltage at low voltage side = 3.7 V  
 Rated voltage at high voltage side = 7.4 V  
 Switching frequency = 20 kHz

#### A. Inductor

Applying the volt-second balance law to L1 during a switching cycle:

$$\frac{D_1}{F_s} \left( V_c + \frac{V_{c21}}{n} \right) - \frac{V_s}{n} (t_2 - t_1) + \int_{t_3}^{t_6} V_{L1}(t) dt + \left( V_c + \frac{V_{c21}}{n} \right) (t_7 - t_6) = 0 \quad (1)$$

From this we get,

$$V_{c21} = \frac{V_s T_s - \delta n V_c - \delta V_s - \sqrt{(\delta n V_c + \delta V_s - V_s T_s)^2 - 4 \delta^2 n V_c V_s}}{2 \delta} \quad (2)$$

In boost mode,

$$(L_1 + L_{s1}) < \frac{D_1^2 (n V_c + V_{c21}) \pi}{2 \pi n I_{discharge} f_s + 2 f_s^2 (k - 1) (n V_c + V_{c21}) C_r} \quad (3)$$

where  $D_1 = 0.4$  and  $f_r$  is given by,

$$f_r = \frac{1}{2 \pi \sqrt{(L_1 + L_{s1}) C_r}} \quad (4)$$

$$(L_1 + L_{s1}) < 4mH \quad (5)$$

Discharging current is calculated as:

$$I_{discharge} = \frac{1}{T_s} \left[ \int_0^{t_1} i_{L1}(t) dt + \int_{t_6}^{t_7} i_{L1}(t) dt \right] \quad (6)$$

$$I_{discharge} = 2A \quad (7)$$

In buck mode, the range of values for inductors  $L_1$  and  $L_{s1}$  is also given by:

$$\frac{10 \pi V_s^2 V_{c21}^2 + k (n V_c + V_{c21}) (V_s + V_{c21}) V_s V_{c21}}{20 \pi V_c I_{discharge} n^2 (V_s + V_{c21})^2} f_s < (L_1 + L_{s1}) \quad (8)$$

$$(L_1 + L_{s1}) > 0.19mH \quad (9)$$

Therefore,  $L_1$  and  $L_{s1}$  are chosen such that it satisfies the equation (5) and (9).

$$L_1 = 2mH$$

$$L_{s1} = 0.2mH$$

Here

$$L_{s2} = n^2 L_{s1} \quad (10)$$

$n$  is chosen as 2, we get  $L_{s2}$  as

$$L_{s2} = 0.8mH$$

$L_{m1}$  is calculated as:

$$L_{m1} = \frac{V_s^2 V_{c21}^2 (L_1 + L_{s1})}{2 n^2 V_c I_{discharge} (V_s + V_{c21})^2 (L_1 + L_{s1}) f_s - V_s^2 V_{c21}^2} \quad (11)$$

$$L_{m1} = 0.47 \mu H$$

Here

$$L_{m2} = n^2 L_{m1} \quad (12)$$

$$L_{m2} = 1.88 \mu H$$

#### B. Capacitor

$C_r$  can be calculated as:

$$C_r = \frac{1}{100 \pi^2 f_s^2 (L_1 + L_{s1})} \quad (13)$$

$$C_r = 1.15nF \quad (3.5)$$

Choose standard value of capacitance that is 2.2 nF.

$C_2$  should be sufficiently large to ensure that the voltage is approximately constant and reduces the voltage stresses of the switches.

$$C_2 > \frac{12(1 - D_3^2)}{(L_{m2} + L_{s2}) \pi^2 f_s^2} \quad (14)$$

$$C_2 > 2.13 \mu F$$

Therefore, choosing a standard value for  $C_2$  as  $3.3 \mu F$ .  $C_1$  is calculated as,

$$C_1 > 4.43 \mu F$$

$$C_1 > \frac{12(1 - D_1^2)}{(L_{m1} + L_{s1}) \pi^2 f_s^2} \quad (15)$$

Therefore, choosing a standard value for  $C_1$  as  $4.7 \mu F$ .

**C. Transformer**

In this system, the E core EE25/13/7 is selected as the transformer core. In order to decrease the value of magnetizing inductance, the air-gap is required in the transformer core. We assume that the turns of primary and secondary windings of transformer T1 are  $N_1$  and  $N_2$ , respectively.

From the calculations we get,  $N_1 = 5 \text{ turns}$  and  $N_2 = 10 \text{ turns}$ . The Standard Wire Gauge (SWG) value for the primary winding is 20 SWG and for the secondary winding it is 22 SWG.

**IV. SIMULATION RESULTS**

The nominal voltage for every single lithium ion cell is 3.7V. If we want higher voltages, we will combine the cells to form the required cell voltage. Since we are using only two cells as reference so the rated voltage at low voltage side will be 3.7V and high voltage side will be 7.4V. In order to perform the simulation, the complete circuit diagram is simulated in MATLAB and the results are shown.

Table. I: Parameters of the proposed bidirectional DC-DC converter

Parameters	Values/Ratings
1. Rated voltage in low voltage side ( $V_c$ )	3.7 V
2. Rated voltage in high voltage side ( $V_s$ )	7.4 V
3. Switching frequency ( $f_s$ )	20 kHz
4. Inductor ( $L_1$ )	2 mH
5. Capacitor ( $C_1$ )	$4.7 \mu F$
6. Capacitor ( $C_2$ )	$3.3 \mu F$
7. Capacitor ( $C_r$ )	2.2 nF

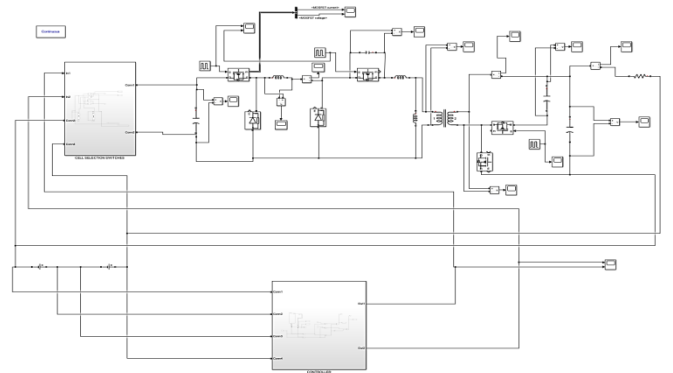

Fig. 6. MATLAB simulation model of equalization circuit in boost mode

Fig. 7. Shows the controller output with a same logic that works like the equalization algorithms. Inside this controller we will be comparing the voltages of every cell in the battery string. If any of the voltage is greater than the reference voltage set, then equalization is activated. If more than one cell is found to have higher voltage than nominal voltage then the greater in them will be selected. The commands are given to the cell selection and polarity switches and they activate the boost mode of operation as shown in fig. 8.

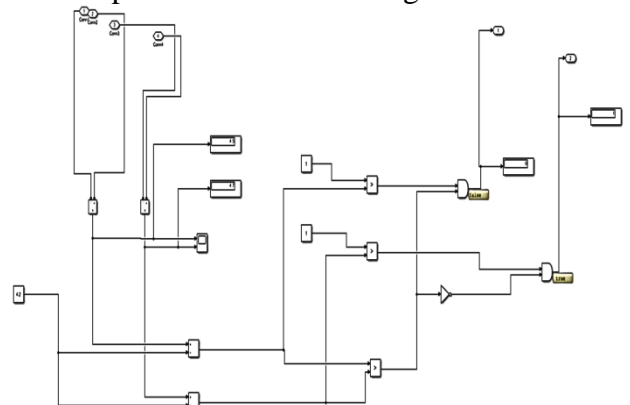

Fig. 7. Controller output in boost mode

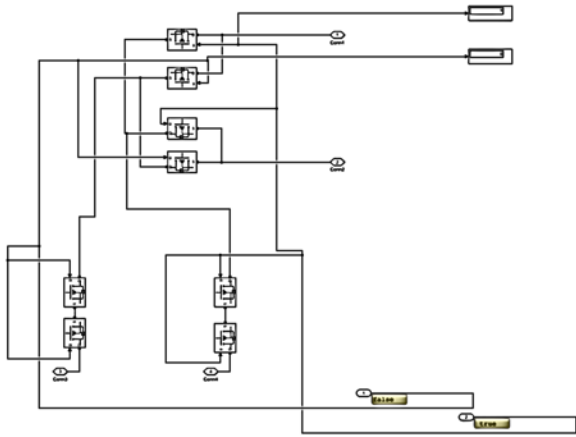

Fig. 10. Controller output in buck mode

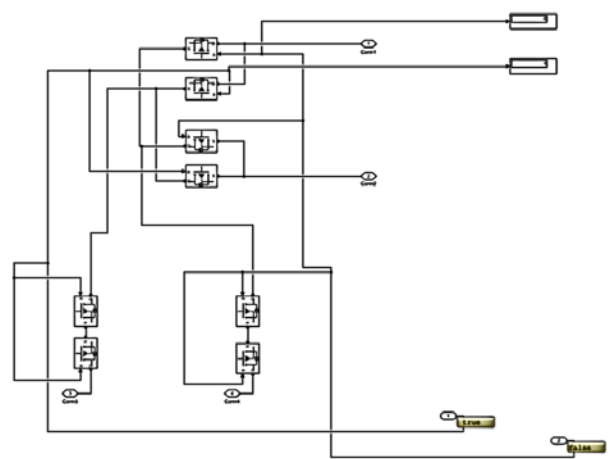

Fig. 8. Cell selection logic output in boost mode  
Fig. 11. Cell selection in buck mode

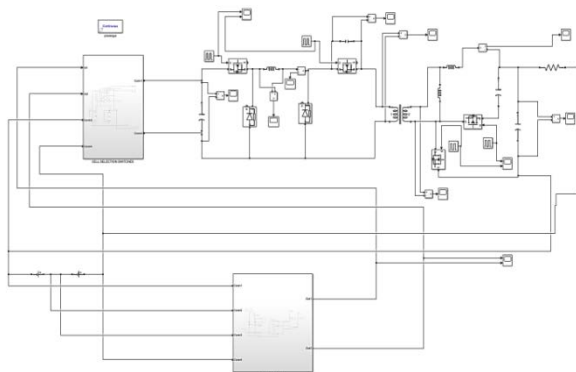
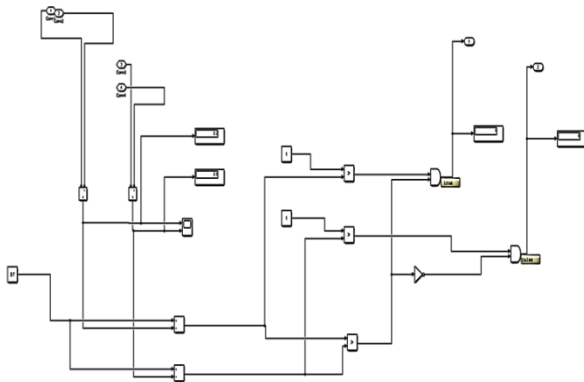

Fig. 9. MATLAB simulation model of equalization circuit in buck mode

The controller will be comparing the voltages of every cell in the battery string. If any of the voltage is less than the reference voltage set, then equalization is activated and the commands are given to the cell selection and polarity switches and they activate the boost mode of operation as shown in fig. 11. If more than one cell is found to have lower voltage than nominal voltage then the most lesser one will be selected.



## V. CONCLUSION

The isolated bidirectional equalizer presented in this paper is having the centralized topology. For a good equalization system, it should persist high equalization speed, high efficiency, small volume, low cost, good extensibility and simple structure. The system is capable for battery string with large number of cells to achieve the real power and voltage for an EV application. Moreover, the equalizer reduces the risk of damage and increases the life of batteries. However, the cost of monitoring IC vary with the increased number of cells.

## ACKNOWLEDGMENT

The authors would like to thank NSS College of Engineering, Palakkad for laboratory support and KSCSTE SARD scheme for providing financial support for procuring equipment.

## REFERENCES

1. M. Yilmaz and P. T. Krein, "Review of battery charger topologies, charging power levels, and infrastructure for plug-in electric and hybrid vehicles," *IEEE Trans. Power Electron.*, vol. 28, no. 5, pp. 2151-2169, May 2013.
2. J. Lu and Y. Wang, "Isolated Bidirectional DCDC Converter with Quasi-Resonant Zero-Voltage Switching for Battery Charge Equalization ", *IEEE Trans. Power Electron.*, 2018.
3. S. Yarlagadda, T. T. Hartley and I. Husain, "A battery management system using an active charge equalization technique based

- on a DC/DC converter topology," *IEEE Trans. Ind. Appl.*, vol. 49, no. 6, pp. 2720-2729, Nov.-Dec. 2013.
4. M. Y. Kim, J. H. Kim and G. W. Moon, "Center-cell concentration structure of a cell-to-cell balancing circuit with a reduced number of switches," *IEEE Trans. Power Electron.*, vol. 29, no. 10, pp. 5285-5297, Oct. 2014.
  5. S. H. Park, K. B. Park, H. S. Kim, G. W. Moon and M. J. Youn, "Single-magnetic cell-to-cell charge equalization converter with reduced number of transformer windings," *IEEE Trans. Power Electron.*, vol. 27, no. 6, pp. 2900-2911, June 2012.
  6. Y. M. Ye, K. W. E. Cheng and Y. P. B. Yeung, "Zero-current switching switched capacitor zero-voltage-gap automatic equalization system for series battery string," *IEEE Trans. Power Electron.*, vol. 27, no. 7, pp. 3234-3242, July 2012.
  7. Y. Guo, R. G. Lu, G. L. Wu and C. B. Zhu, "A high efficiency isolated bidirectional equalizer for Lithium-ion battery string," in *Proc. IEEE Veh. Power Propulsion Conf.*, 2012, pp. 962-966.
  8. J. L. Sun, C. B. Zhu, R. G. Lu, K. Song, and G. Wei, "Development of an optimized algorithm for bidirectional equalization in lithium-ion batteries," *J. Power Electron.*, vol. 15, no. 3, pp. 775-785, May 2015.
  9. C. H. Kim, M. Y. Kim and G. W. Moon, "A modularized charge equalizer using a battery monitoring IC for series-connected li-ion battery strings in electric vehicles," *IEEE Trans. Power Electron.*, vol. 28, no. 8, pp. 3779-3787, Aug. 2013.
  10. M. A. Hannan, M. M. Hoque, S. E. Peng and M. N. Uddin, "Lithium-ion battery charge equalization algorithm for electric vehicle applications," *IEEE Trans. Ind. Appl.*, vol. 53, no. 3, pp. 2541-2549, May-June 2017.
  11. M. Rawson and S. Katele, "Electric Vehicle Charging Equipment Design and Health and Safety Codes", SAE International by Univ of California Berkeley, August 01, 2018.
  12. R. Fatimaa, A. Ahmed Mirb, "Testing Study of Commercially Available Lithium Ion Battery Cell for Electric Vehicle ", *IEEE International Conference on Power, Energy and Smart Grid (ICPESG 2018)* on 9-10 April 2018.