



IOT DEPENDENT GREEN HOUSE MONITORING SYSTEM

M.Harika¹, G.Manimala², D.Deepika³, N.Ganesh⁴, S.Zubaid Ahmed⁵

¹Assistant Professor, ^{2,3,4,5} Final Year Students

Department of Electronics and Communication Engineering

Satya Institute of Technology and Management, Andhra Pradesh, India¹

¹harika1881995@gmail.com

²manimalagudimella99@gmail.com, ³doddadeepika8@gmail.com,

⁴ganeshnetheti123@gmail.com, ⁵zubaidahmed99@gmail.com,

Abstract

IOT dependent Greenhouse monitoring system is the new approach in which the farmers in the rural areas will be Pro fitted by automatic monitoring and control of greenhouse environment. It replaces the direct supervision of the human. In this project we have proposed a system based on the disadvantages of present monitoring system. Greenhouse may be a building where plants are grown during a controlled manner. Nowadays due to urbanization and less land availability there is a great need to construct the Greenhouses which will be reserved mainly for growing crops.

I. INTRODUCTION

Green home is a structure with walls and roof made mainly of transparent material like glass which plants requiring regulated climate are grown. Green house structure aim size from small sheds to industrial sized buildings. miniature greenhouse is understood as a chilly frame. interior of greenhouse exposed to sun light becomes significantly warmer than the external temperature, protecting its contents in climatic conditions. Different techniques are then accustomed evaluate optimally degrees and luxury ratio of greenhouse so on cut back production risk before cultivation of a specific crop.

II. LITERATURE SURVEY

lack of food stuffs in our nation. This is because of the increased population. Our food crops need specific environmental conditions for their growth. The huge variation in the environmental conditions in the present ,will

affect the growth of the crops. Because of medicinal plants are not more available, also there is an unavailability of labour in the present .From all these problems we realized that there must be need for automatic monitoring and system for greenhouse which is the place we can cultivate the crops under specific conditions suitable for it.

III. PROBLEM DEFINATION

Many issues involved in monitoring climatic parameters like humidity, soil moisture, illumination, soil pH, temperature etc., which directly or indirectly affects the plant growth. Investment within the automated process are high, as today's greenhouse control systems are designed for fewer than one parameter monitoring to manage quite one parameter simultaneously there will be a necessity to shop for quite one system. High maintenance and wish for skilled technical labour. the fashionable systems use the mobile technology because the communication schemes and wireless data acquisition systems, providing global access to the knowledge about one's farms. But it suffers from various disadvantages like design complexity, inconvenient repairing and high price. Also the reliability of the system is relatively low, and when there are malfunctions in local devices, all local and tele data are visiting be lost and hence the whole system collapses. Moreover farmers in India don't work under such sophisticated environment and find no necessity of such a sophisticated system, cannot afford the identical. Keeping these issues visible , an IOT based monitoring and system is supposed to hunt out implementation within the near future

which can help Indian farmers.

IV. EXISTING METHOD

Agriculture in India is still carried out in traditional way and lags behind in integrating new technologies. Around 55% of Indian population has been engaged in agriculture and allied activities which constitute only 15% of GDP so it becomes much important for the stakeholders involved to come out of the conventional agriculture practices and modernize the agriculture using technology. Hence, there is an immediate need to improve the system, which can increased the yield and produce healthy organized crops.

V. PROPOSED METHOD

Internet of things connects the available physical objects with internet in order that they might be accessed through internet and during this each physic-al object is assigned with and IP address thus making them capable for collecting and transferring a knowledge over a network with none manual invention. And internet of thing comprises of physical objects, controller, and internet. The proposed system include micro controller Arduino various sensors like temperature, humidity, light and smoke sensors and windows application for controlling green house and parameters inside green house. just in case any un favourable situations arises, it then takes the specified operation. And when sensors reach a threshold it'll send the signal to the microcontroller and required action are going to be taken.

VI. BLOCK DIAGRAM

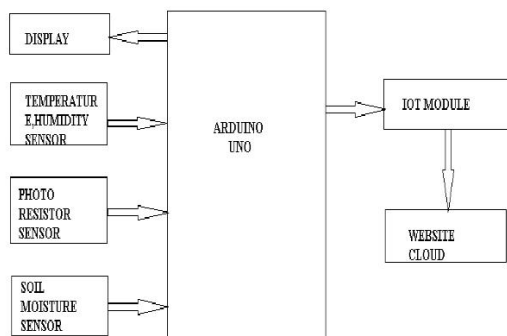

VII. RESULTS

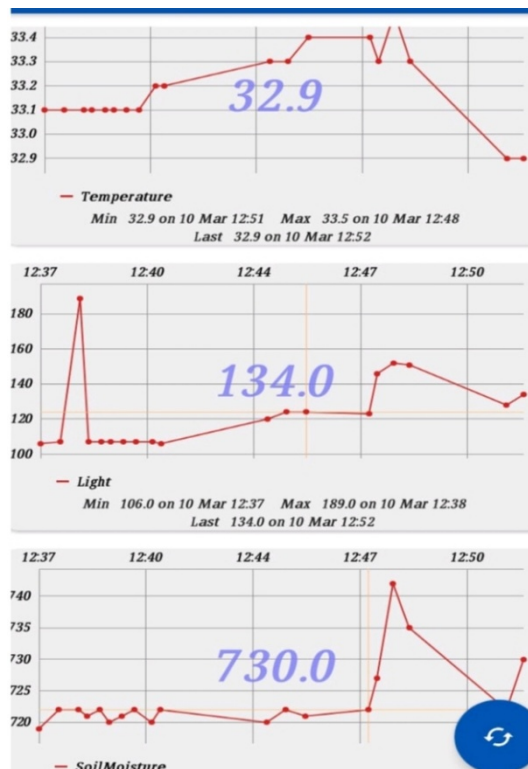

VIII. CONCLUSION

Hence by using this method growth factors of plants like temperature, humidity, light are often monitored and controlled effectively.

IX. REFERENCES

[1] Tanu Saha, Ashok Verma, “Automated Smart Irrigation system using Arduino”, International Journal of computer applications, Vol 172-No.6, August 2017.

[2] Bhagyashree K.Chate , Prof.J.G.Rana “ Smart Irrigation System Using Arduino”, IRJET May,2016.

[3] N.B. Bhandarkar, D.P. Pande, R.S. Sonone, Mohd. Aaquib, P.A. Pandit, International Journal of Current Engineering and Technology, Vol. 4, No. 5, Oct 2014.