



## IOT-BASED INTELLIGENT ROBOT

Varamahalakshmi O<sup>1</sup>, Karthik Kumar K N<sup>2</sup>, Touqhir Pasha A<sup>3</sup>

Vinay Kumar N<sup>4</sup>, Kandu Kuri Mourya<sup>5</sup>

4th year, BE, Department of Telecommunication Engineering, SJCIT, India

<sup>1</sup>[varu.o92@gmail.com](mailto:varu.o92@gmail.com),

<sup>2</sup>[knkarthik13@gmail.com](mailto:knkarthik13@gmail.com), <sup>3</sup>[touqhirpasha1999@gmail.com](mailto:touqhirpasha1999@gmail.com)

**Abstract**— nowadays development of IoT applications with robotics is an ongoing reevaluation. This paper mainly focuses on the security, remote surveillance, and monitoring of our homes done by the surveillance robots. Remote surveillance has become the most important research topic over the past decade. Through this paper we put forward a surveillance robot that can be used in domestic areas and many other places. Robots are becoming important in our day to day life activities as they reduce the human labor and probability of error. We can control robots manually or they can be automatic based on the need of people. This paper focuses on design and implementation of mobile robot for obstacle detection and avoidance in a real-time basis.

**Keywords**—Surveillance, IoT, Raspberry Pi, PIR, Robot

### I. INTRODUCTION

Innovation has gotten a dynamic and enormous change mechanical technology and mechanization field which runs in a wide range of regions. Surveillance is the procedure of close deliberate perception or supervision kept up over an individual, gathering, and so forth particularly one in care or under doubt.

Traditionally surveillance is done by systems which are installed in every security critical areas. These systems mainly consist of high quality cameras, multiple computers for monitoring, servers for storing these videos [1]. The installing of these systems everywhere is a complex task and also requires heavy maintenance. Thus surveillance is for the most part required in the territories where the frameworks cannot be introduced, for example,

outskirt zones, open spots, workplaces and in ventures. It is primarily utilized for observing exercises. The demonstration of surveillance can be performed both indoor just as in open air regions by people or with the assistance of implanted frameworks, for example, robots and other robotized gadgets. A robot is only a programmed electronic machine that is fit for performing modified exercises in this manner supplanting human work, giving exceptionally exact outcomes and effectively beating the restrictions of people. In this manner people are being supplanted by robots and it is one of the incredible progressions in mechanical autonomy. The robot comprises of Raspberry Pi 3 model B microcontroller which is utilized for making robot remote and online and the recordings are transmitted remotely from the robot to client's screen. This robot additionally comprises of DC engines, wheel case, battery, Wi-Fi module (ESP8266 12e) and different kinds of sensors, for example, ultrasonic sensor for obstacle detection, IR sensor for identifying pits and furthermore the PIR sensors for obstacle avoidance [2]. We can operate the robot manually by using keys to give commands or it can be operated automatically. IOT innovation is assuming a pivotal job in headways of different business areas like business the executives, producing, keen shrewd vehicle framework, agribusiness, autos and even mechanical technology. Using the concept of Internet of Things user can communicate with the robot or can get information of that particular area where the robot is sent for surveillance. For developing the IoT projects there is IoT software named CAYENNE [3]. In this software the commands are sent to robot through software and they are received by

Raspberry Pi via Wi-Fi module (ESP8266) as both are interfaced with each other. From using these software and modules we can control the robot in a wireless manner. In this research paper, we use wireless transmitting camera that provides images and video information that can be received at the user end. This information is very useful for security purposes in many hospitals, malls, defense areas, etc.

The main purpose of this robot is to monitor places remotely and can get an audio or video as information from the environment to the user. In this venture, the robot can be controlled through versatile or workstation utilizing Web of Things (WoT) and furthermore can give the live gushing of video with the assistance of remote camera implanted in robot. The robot can be controlled both in manual just as in computerized mode with the assistance of Raspberry Pi microcontroller [4]. This robot likewise utilizes different sensors that gather information and sends it to the Raspberry Pi microcontroller which controls the robot conduct. Alongside the got live gushed video yield. Along these lines, the activity of observation can be performed. Further headway in our venture can give observation even in protection zones naturally [5].

Our main contribution is to develop a cost-efficient IoT based surveillance robot that can monitor and control the system. Rest paper organized as follows: In Section II, a literature part is presented and getting important data about the status and environment conditions. The proposed system is the subject of Section III. System implementation is addressed in Section IV. Conclusions and Future Work is given in Section VI.

## **II. MOTIVATION AND RELATED WORK**

Surveillance is done in many fields through systems installed everywhere wherever needed. These systems only monitor the place where the yare installed and also they have limited range. Traditionally, we have to install these systems everywhere and it consists of high cost and heavy maintenance. But in today's world we need systems that can roam around everywhere to survey the environment and give the live streaming videos of that environment. The solution for all the issues is to have a surveillance robot which can roam around anywhere to monitor any place. When an

intrusion happens then it can notify the user. The user can monitor the robot from a remote location. So that robot can easily be used by any user. We can control the surveillance robot through our phones or laptops so that from anywhere we can control the robot. We can take images and also record videos to collect proofs if any crime happens. For finishing this undertaking, we require a Raspberry Pi, Pi camera, a force supply for the Raspberry Pi, Robot skeleton and an android telephone for the live gushing and controlling of our robot. We use Linux based Working framework for Raspberry Pi and Pi camera configuring files and a motion software for recording the video from our cell phone. In order to achieve cost efficiency and maintenance, we have proposed an IOT based surveillance robot that will survey the environment.

Various authors had discussed about various aspects of different types of observing activities and tracing applications.

In the paper [6] the author presented "Intelligent surveillance and security robot systems" published on 28 Oct. 2010 IEEE Workshop on Advanced Robotics and its Social Impacts which was held at Seoul, South Korea. This paper presents for this are also costly. Another point is that the signal strength may not be strong enough to reach every area, leaving portions of the location unmonitored. Also, bad weather can interfere with the signal of these systems. The purpose of the proposed system will be to eliminate the drawbacks of a new security solution that integrates vision, intelligent algorithm and robot technology. While conventional security solutions rely on human operator's vigilance on the images provided by cameras, the proposed solution uses machine intelligence to compensate for human factors and robots to provide immediate counter response.

In the paper [7] presented "System and Software architecture for autonomous Surveillance robots in urban environments" published in 2012 9th International Conference on Ubiquitous Robots and Ambient Intelligence (URAI) which was held in Daejeon, South Korea. In this paper, they propose a system of the security robot and its software architecture. The proposed system and software architecture will make a robot to perform security missions. In this paper [8] the authors presented

“Development of a mobile Surveillance robot” Published in 17-20 October 2007 International Conference on Control, Automation and Systems which was held at Seoul, South Korea. In this paper, a simulation based design scheme has been adopted to develop a mobile order to compensate the motion of the vehicle which experiences the rough terrain.[9]

Jung-Hyun Park; Kwee Bo Sim [4] presented “A design of mobile robot based on Network Camera and sound source localization for intelligent surveillance system”, Published on 02 December 2008 International Conference on Control, Automation and Systems which was held at Seoul, South Korea. This paper proposes the system which complements the vulnerability. Purpose of this paper is loading network camera and tracking module of sound source in mobile robot based on embedded Linux for tracking intruder.

Existing System

Frameworks which are already made use surveillance robots that have limited scope of correspondence as they depend on RF Innovation, ZigBee and Bluetooth. They have short range remote camera so they can't catch the pictures which are not secured by the locale of camera. These robots can only be controlled with a manual mode which needs human supervision all through the entire observation process [7]-[11].

III. PROPOSED SYSTEM ARCHITECTURE

In this project we make a remote control car which has a view via an attached camera. This car is controlled from a laptop or mobile in a remote location. User can view the things according to the camera installed in the robot. The robot utilizes a pan tilt motor that moves camera around so that the user can see everything going on from where the robot is. It connects with the Wi-Fi and then we can control the robot from mobile or computer.

We are build in ga remote controlled wireless surveillance monitoring framework utilizing Raspberry Pi mounted on a robotic vehicle. This could be a helpful and reasonable secure and spy instrument, which have numerous configurable alternatives. In this IOT venture we are mostly utilizing Raspberry Pi, USB web camera and two DC engine with Robot case, to construct this Mechanical vehicle.

We will build up a robot which can be utilized for video observation and checking that can be controlled through a GUI. The control component is provided a video transmission facility. The video transmission is for all intents and purposes accomplished through fast picture transmission.

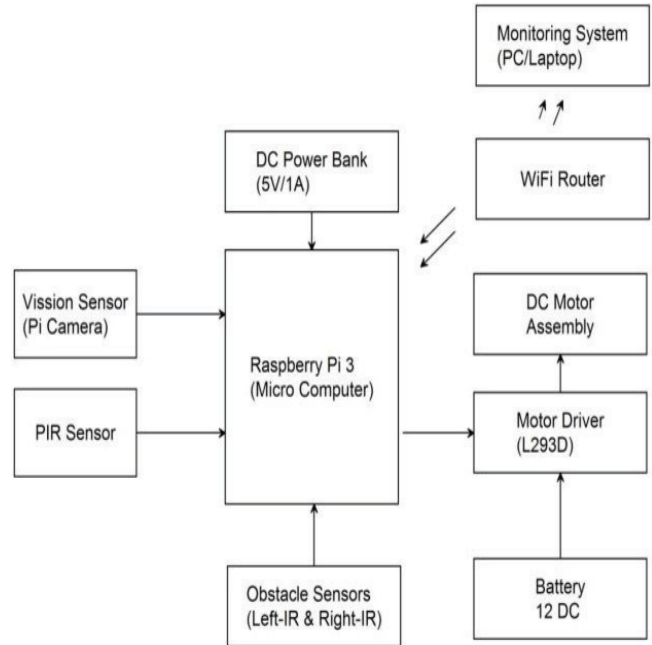

Fig. 1. Block diagram of proposed System

Figure 1 shows the block diagram of proposed system that uses the Raspberry pi as processing unit that connected the sensors and utilizes the physical quantity for decision making.

System Design

Structure of the surveillance robot consists of two components:-

- Chassis
- Locomotion

Robot Chassis comprise the body of a robot. Roll cages, bumpers and other body accessories can also be found in this category. This chassis plate is used with our custom length robot platform. Locomotion is used for the movement of the robot according to the obstacles found.



Fig. 2. Overview of IoT based Robot

Figure 2 shows the robotics process of the system how the system work and monitor the real world. Different types of sensors like PIR sensor, Ultrasonic sensor, etc. are used to sense the environment and give the input to do some action.

The distance sensor used is LV-MaxSonar-EZ0 High performance Ultrasonic Range Finder. The sensor outputs distance in the form of an analog output on one pin, and has additional pins for power and toggling the sensor on and off. The analog pin is connected to an analog to digital (ADC) pin on the microcontroller. The Brain of the robot is the microcontroller system in which the programming is done to give the particular output. Raspberry pi is a small credit-card sized computer capable of performing various functionalities such as in surveillance systems, military applications, etc. This makes Internet of Things device cable-free by adding Wi-Fi. Its advantages include low cost, but high-reliability wireless link. For generating the output we use the motor

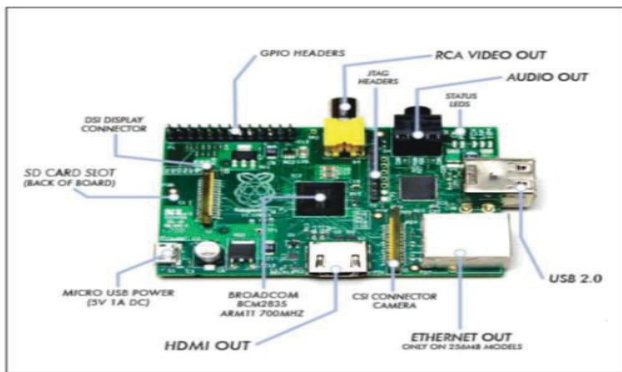

Fig. 3. Raspberry pi-3

Figure 3 shows the Raspberry pi-3 and their components which are connected with different sensors. A DC motor is used to drive the robot for that we use 500 rpm 4 dc motor. The speed of the motor is dependent on the diameter of the wheel and rpm of the motor. Engine Driver IC L293D is a dual H-bridge engine driver incorporated circuit (IC). Engine drivers go about as current amplifiers since they take a low-current and flow control flag and give a higher-current and flow signal. This higher current signal is utilized to drive the engines.

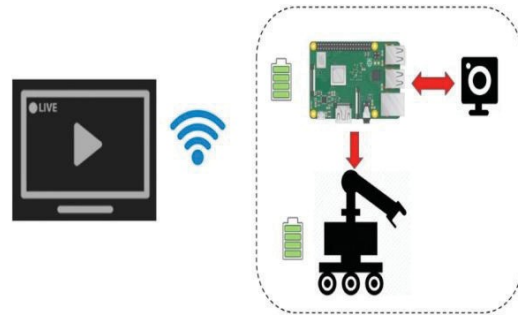

Fig. 4. Proposed Robot model

The above figure 4 consists of the basic model of the system connections and the interdependencies of each block on each other. Power supply is given to IC driver L293D and this supply is further given to two decimators. Camera module and Raspberry Pi is mounted on robot for surveillance.

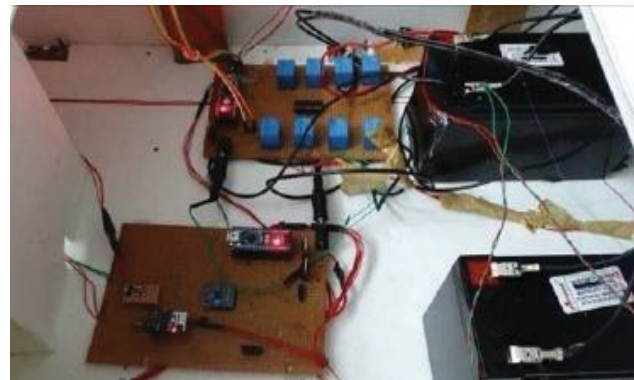

Fig. 5. Internal Circuit of IoT Based Robot

In figure 5 we describe the internal circuit of the proposed robot system; here we connect all sensors with the center processing unit and according to the collected data to take decisions.

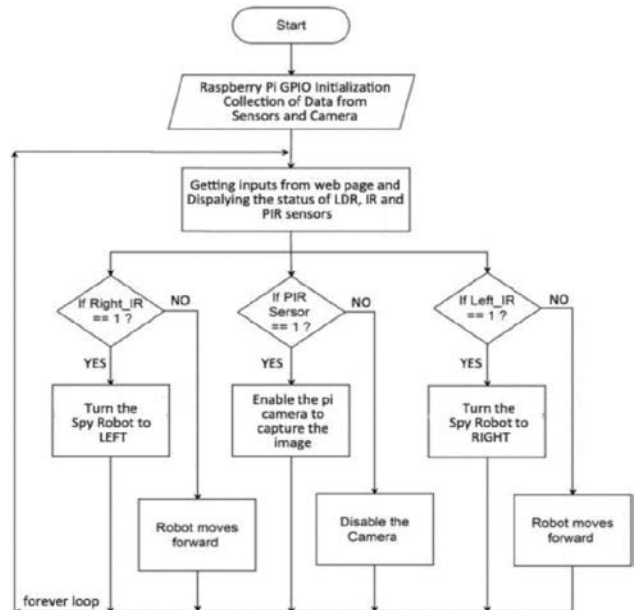

Fig. 6. Flow of Process

Figure 6 shows the process flow of the proposed system and shows how the information should flow. Firstly collected information from sensors

went into the board and then the movement of robot will be decided by the central unit.

#### IV. RESULT ANALYSIS

In this section we discussed the result analysis of the proposed research work. Figure 7 shows the detection rate with values of similarity.

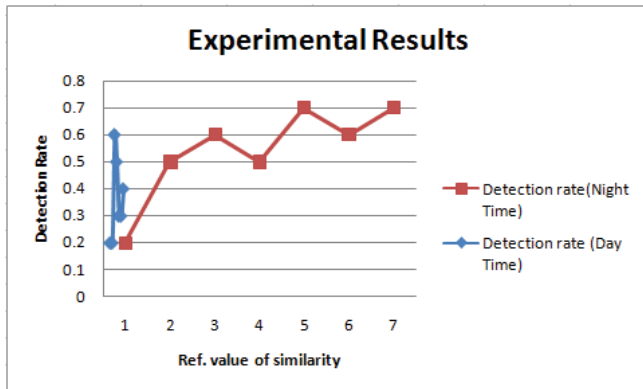

Fig. 7. shows the experimental result of proposed system

#### V. CONCLUSION

In this paper we comprise the structure for making a surveillance robot. The surveillance robot will be intended to convey a sensible degree of effectiveness and effortlessness, giving every client a streamlined client experience. The surveillance robot is made to give checking comprehensive of vision, movement. In view of measured structures and complete versatility, the surveillance robot is intended to be expandable and take into consideration future control overhauls, therefore improving the openness soft he client and giving a proficient way out of the custom framework. This gives exceptionally productive and a financially savvy robot that replaces human work and lessens human work and performing checking works in a successful way.

#### ACKNOWLEDGMENT

We acknowledge the support of GLA University for giving us a chance to do something that is useful for the society and for providing the fund for research work and the proposed system.

#### REFERENCES

[1] Mohammad Shoeb Shah, Borolo. P.B. "Surveillance and Rescue Robot Using Android Smart Phone And Internet". International Conference on Communication And Signal Processing, India.(2016)

[2] G. Anandravisekar, A. Anto Clinton, T. Mukesh Raj, L. Naveen, UG Students, Department Of Electronics and Communication

Engineering Saranathan College Of EngineeringTrichy, Tamilnadu,India

[3] Dr. Shaik Mahaboob Basha, Abdul Khayyum. S.K, Amarendra.B, Sajid.S.K. "Design Of Security Robot in Night Vision Using Wireless Video Camera And Ultrasonic Sensor" Geethanjali Institute of Science And Technology, Nellore, Andhra Pradesh, India.(2017)

[4] Ki Sang Hwang ;KyuJin Park ; Do Hyun Kim, "Development of a mobile Surveillance robot", 17-20 October 2007 International Conference on Control, Automation and Systems which was held at Seoul, SouthKorea.

[5] T.M. Sobh ; R. Sanyal ; Bei Wang, "Remote surveillance via web- controlled mobile robots", Proceedings World Automation Congress, 20 June 2004 , Seville ,Spain.

[6] Ashish U. Bokade ; V. R. Ratnaparkhe , "Video robot control using smartphone and Raspberry pi", 24 November 2016 International Conference on Communication and Signal Processing (ICCSP), Melmaruvathur,India.

[7] Grieco, L. A., Rizzo, A., Colucci, S., Sicari, S., Piro, G., Di Paola, D., &Boggia, G. (2014). IoT-aided robotics applications: Technological implications, target domains and open issues. *Computer Communications*, 54,32–47.

[8] Gubbi, J., Buyya, R., Marusic, S., &Palaniswami, M. (2013). Internet of Things (IoT): A vision, architectural elements, and future directions. *Future Generation Computer Systems*, 29(7),1645–1660.

[9] Nayyar, A., &Puri, V. (2016, March). A review of Arduino boards, Lilypad's& Arduino shields. In *Computing for Sustainable Global Development (INDIACom)*, 2016 3rd International Conference on (pp. 1485–1492).IEEE.

[10] Nayyar, A., &Puri, V. (2016). Smart farming. In *Communication and Computing Systems* (pp. 673–680). CRCPress.

[11] Nayyar, A., Puri, V., Nguyen, N. G., & Le, D. N. (2018). Smart surveillance robot for real-time monitoring and control system in environment and industrial applications. In *Information Systems Design and Intelligent Applications* (pp. 229-243). Springer, Singapore.