



VOICE ACTUATED HOSPITAL BED CONTROL, MONITORING AND ALERTING SYSTEM USING BLUETOOTH AND IOT

¹Akshata chavan, ²Chetana V Puradal, ³Keerthana S, ⁴Adarsh G B, ⁵Musaddiq Ahamed
¹akshatachavan@gmit.ac.in, ²chetanapuradal19@gmail.com, ³keerthanakeeru205@gmail.com
, ⁴adarshgb819@gmail.com, ⁵musaddiq749@gmail.com

Abstract— Now a days due to increasing in medical problems, so the patient expects so many advance facilities in hospital. The patient should feel comfortable in hospital. So concentrating on patient's asset and safety we have designed this system. The main aim of this system is the movement of bed according to patient requirement. To give the command system has used UART Bluetooth module to connect speech recognition system and microcontroller. The speech recognition system is installed in mobile. The system makes use of the speech recognition system, servo motors, a microcontroller (Arduino UNO), temperature sensor and heartbeat sensor .

Index Terms—Arduino UNO, ThingSpeak, Voice Command.

I. INTRODUCTION

The main aim of designing the system is to feel patient relief from each Hassel and also to make sure of each safety. The system is very helpful for paralysed and physically ill person in hospital to control their bed height by themselves. The microcontroller is capable of communicating with all input and output modules. The voice recognition system which is the input module to the microcontroller takes the voice instruction gives by the user as input instruction is to lift upward or to the downward and according to the user's voice command, the appropriate action will be performed. To control the bed height two servo motors are used. The motor for head side and leg side. Also, the temperature of the patient is continuously monitored on LCD. This system also has a buzzer alarm system which is horned if patient crosses the normal temperature and if it feels

panicked.

Speech recognition is the process of recognizing the spoken words to take the necessary actions accordingly. User can also control the electrical devices like fan, light, door etc. with the help of voice recognition system. This device is very helpful for paralysis, and physically challenged persons especially in hospitals to control their bed height by themselves. The speech recognition system provides the communication between the user and the microcontroller-based bed control mechanism. This project makes use of a DC motor for moving the bed based on the voice/speech commands given by the user and voice recognition chip is used for recognition of the voice commands. Also, switches Relay are interfaced to controller to which electrical appliances are connected. Microcontroller is programmed, with the help of embedded C instructions. The microcontroller is capable of communicating with all input and output modules. The voice recognition system which is the input module to the microcontroller takes the voice instructions given by the user as input and the controller judges whether the instruction is to lift upwards or to the downwards or to control electrical devices, and according to the user's voice command, the appropriate action will be performed. Also, LCD display is available for visual information of operations being performed.

II. SYSTEM REQUIREMENTS

A. Software requirements

- Arduino IDE
- ThingSpeak
- Android application

B. Hardware requirements

- Regulated Power Supply
- Arduino UNO
- Heartbeat sensor
- Temperature sensor
- Wi-Fi Module
- Bluetooth Module
- LCD Display
- L298
- Buzzer
- Servo Motor
- Relay
- Fan
- Light
- Jumper wires

III. BLOCK DIAGRAM

The block diagram consist of main bed control through voice and monitoring parts. They are temperature and panic. The main part of the system is to control bed which totally. works on command. The command given to the gives is through programming. Total 4 commands has being used they are either up or down head side and leg side. Only one command will work at a time. The use of android phone in the system to record the voice i.e. to give the commands. The Bluetooth of android system is connected to UART Bluetooth what even the command has being recorded it will send to Bluetooth and then Bluetooth will transmit it to microcontroller. As Bluetooth transmitter pin has been used and microcontroller receiver pin has been used. The microcontroller will function according to command it will check in coding and then it will precede the function. Whatever commands has been given by the person will go to the driver IC and then the movement of bed is takes place. To measure the temperature of patient body system uses Temperature sensor which will sense the temperature of the patient body. The temperature which is sensed by Temperature sensor in analog form. The microcontroller will convert it into digital form as it has inbuilt ADC. The measured temperature is in ⁰C but the displayed temperature is in ⁰F and ⁰C by using formula.

The calculated output will give to LCD to display the current temperature of patient. we have set some temperature i.e. 40⁰C if patient crosses this temperature one alert system will be given to the doctor and buzzer will horn. This is a panic switch which is available nearby

patients’ bed. If the patient feels any type of panic he/she will push the button. The command will give to the microcontroller. The microcontroller will give two outputs. First is the alert message and second to horn the buzzer. If we need air and just say Fan ON and Fan will be ON. If we want Light and say light ON and light will be ON.

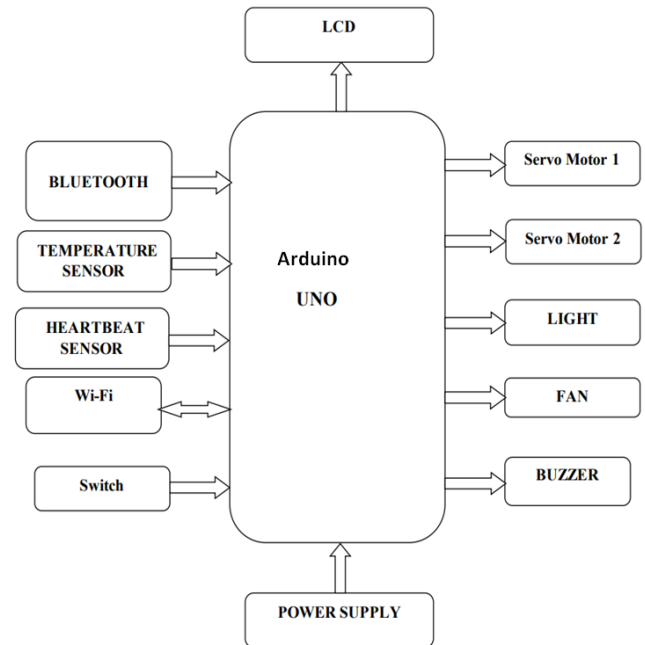

Figure 1: Block Diagram of voice actuated hospital bed control, monitoring and alerting system

IV. DESIGN AND DEVELOPMENT OF VOICE ACTUATED HOSPITAL BED CONTROL, MONITORING AND ALERTING SYSTEM USING BLUETOOTH AND IOT

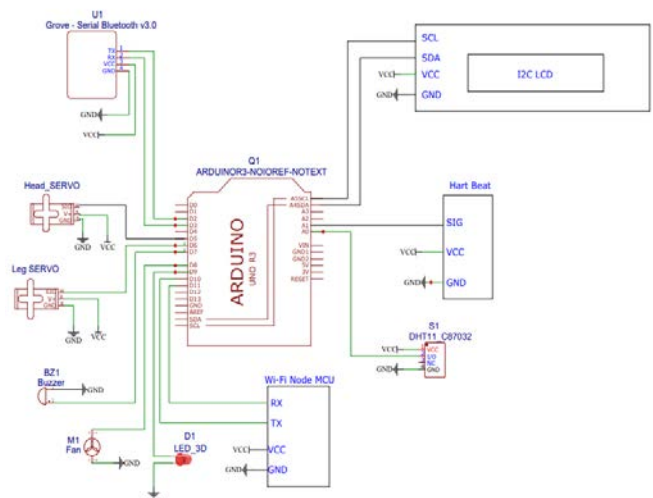

Figure 2: Circuit diagram of hospital bed management

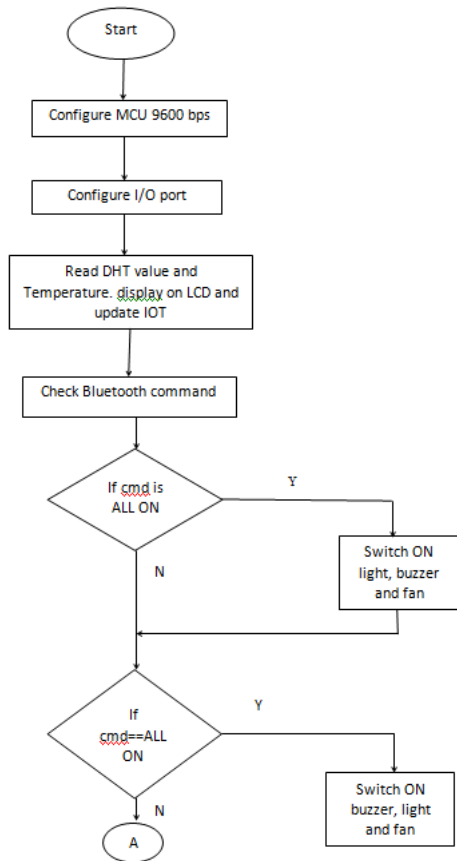

Figure 3: Main control Algorithm Flowchart

V. MECHANICAL SUBSYSTEM CONCEPTUALIZATION

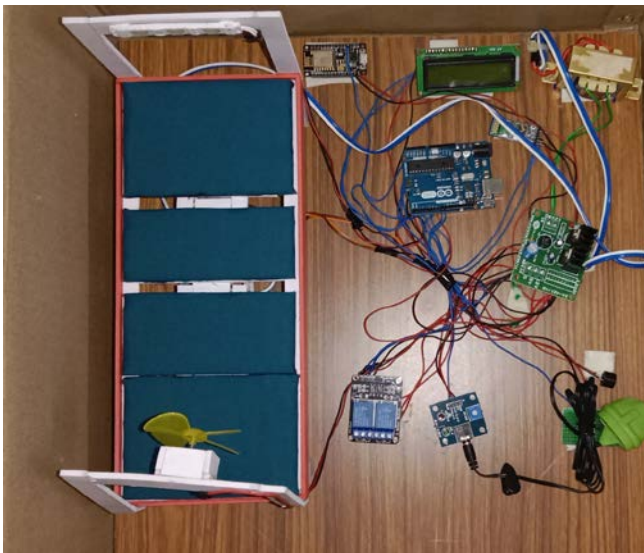

Figure 4: Prototype model of voice actuated hospital bed control, monitoring and alerting system using Bluetooth and IOT

A. Connection to IOT

ThingSpeak is an IoT analytics platform service that allows you to aggregate, visualize, and analyze live data streams. Once you send data to ThingSpeak from your devices, you can create instant visualizations of live data without having to write any code. With MATLAB® analytics

inside ThingSpeak, you can write and execute MATLAB code to perform more advanced preprocessing, visualizations, and analyses. Get started with building your IOT systems without setting up servers or developing web software. The Integration with The Things Network allows you to seamlessly forward data from The Things Network to ThingSpeak for analysis and visualization.

Setup ThingSpeak

- Create a free MathWorks account or sign into ThingSpeak using an existing account.
- Select the ThingSpeak channel you want your data to stream into. See Collect Data in a New Channel for help creating a new channel.
- Record the following for the selected channel:
 1. Channel ID, which is listed at the top of the channel view.
 2. Write API key, which can be found on the API Keys tab of your channel view.

Create Integration on The Things Network

- In The Things Network Console, go to your application and click on Integrations > add an integration > ThingSpeak.
- Enter your write API key in the Authorization field and your channel ID in the Channel ID field.

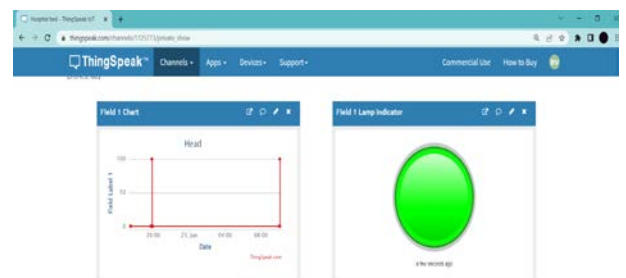

Figure 5: ThingSpeak display for head position

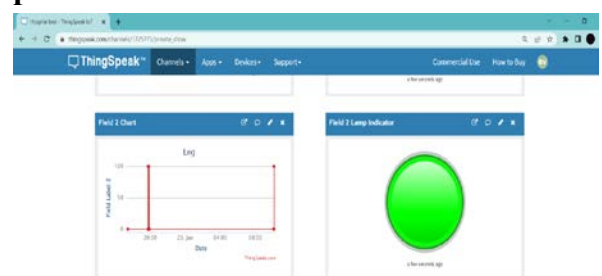

Figure 6: ThingSpeak display for leg position



Figure 7: ThnigSpeak display for temperature monitoring

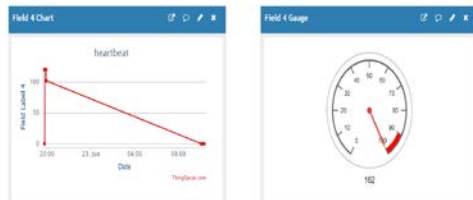

Figure 8: ThnigSpeak display for heartbeat monitoring

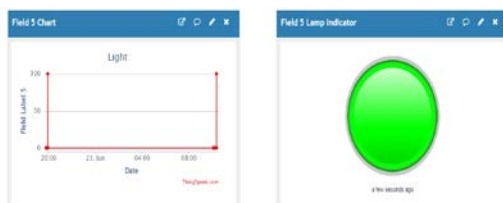

Figure 9: ThnigSpeak display for light

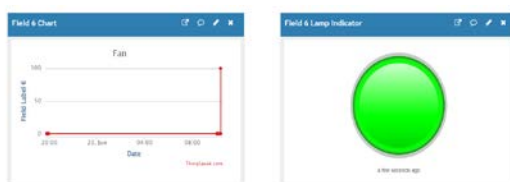

Figure 10: ThnigSpeak display for fan

VI. CONCLUSION

The developed intelligent bed actuated using voice commands, put the bed in a motion responding to the user's voice and also the bed inclined and reclined at precise angles. ATmega328 was used to control the logic level of this system which drove the motor driver circuit for every voice input from the user was initiated. Extension of the same prototype will make it more advance and help us combat the disadvantages faced. Overall, our proposed prototype of the Hospital Bed is made eco friendly without any signals which are hazardous for the Hospital environment even after the system is wireless.

REFERENCES

- [1] A. Alice Linsie, "Voice Activated Hospital Bed, Herat Beat, Temperature Monitoring and Alerting System 647", International Journal of Advanced Research in Electrical, Electronics and Instrumentation Engineering, (An ISO 3297: 2007 Certified Organization), Vol. 3, Issue 11, November 2014.
- [2] G. Panik, "Voice Operated Intelligent Wheelchair", International Symposium on Industrial Electronics, (ISIE 2005). Xplore on 14 November 2005.
- [3] Ignacio Gherzi, M Mariño, M T Miralles, "Modern Push-Button Hospital-beds to 20th Century Mechatronic Beds" A Review, Journal of Physics: Conference Series 705 (2016) 012054
- [4] Tawfik, "Smart Beds" published in 2008 Advances in Science and Engineering Technology International Conferences (ASET). Xplore on 11 June 2018.
- [5] Yudi Zhu, "Wheelchair Automatic Docking Method for Body-Separated Nursing Bed Based on Grid Map" IEEE Access. Xplore on 28 May 2021
- [6] Shih-Wei Peng, "Mechanism Design and Mechatronic Control of a Multifunctional Test Bed for Bedridden Healthcare", IEEE/ASME Transaction on Mechatronics (volume:15, Issue:2, April 2010). Xplore on 27 May 2009.
- [7] Wei Zou, "Contour Detection and Localization of Intelligent Wheelchair for Parking into and Docking with U-Shaped Bed", 2011 IEEE International Conference on Robotics and Biomimetic. Xplore on 12 April 2012