



ELECTRIC POLE, TRANSMISSION LINE PROTECTION AND LINEMAN SAFETY

¹Sujata Eresimi, ²Bharath G S, ³Kiran U, ⁴Kiran R, ⁵Naveen kumar K

¹Assistant Professor, ^{1,2,3,4,5}EEE Department, Jain Institute of Technology, Davangere -577003

ABSTRACT

When operated manually we see fatal electrical accidents to the line man are increasing during the electric line repair due to the lack of communication and coordination between the maintenance staff and the electric substation staff. In order to avoid such accidents, the breaker can be so designed such that only authorized person can operate it with a password. This ensures security of the worker because no one can turn on the line without his permission. The system is fully controlled by the 8 bit microcontroller of at mega 328 family. The password is stored in an EEPROM, interfaced to the microcontroller and the password can be changed any time unlike a fixed one burnt permanently on to the microcontroller. A keypad is used to enter the password and a relay to open or close circuit breaker, which is indicated by a lamp. Any wrong attempt to open the breaker (by entering the wrong password) an alert will be actuated, indicated by another LED.

INTRODUCTION

Now days, electrical accidents of the line man are increasing while repairing the electrical lines due to lack of communication between the electrical substation and maintenance staff. This paper gives a solution to this problem to ensure line man safety. In this proposed system the control (ON/OFF) of the electrical lines lies with line man. This paper is arranged in such a way that maintenance staff or line man has to enter the password to ON/OFF the electrical line. Now if there is any fault in electrical line then line man will switch off the power supply to the line by entering

the password and comfortably repair the electrical line, and after coming to the substation line man switch on the supply to the particular line by entering the password. Here, there is also a provision of changing the password. Circuit breakers are actually provided as a means of protection to completely isolate the downstream network in the event of a fault. The demand for electrical energy is ever increasing. Today over 21% (theft apart!!) of the total electrical energy generated in India is lost in transmission (4-6%) And distribution (15-18%). The electrical power deficit in the country is currently about 18%. Electric power is normally generated at 11-25kV in a power station. To transmit over long distances, it is then stepped-up to 400kV, 220kV or 132kV as necessary. The demand for electrical energy is ever increasing; to overcome this problem Load sharing concept is included. This paper focusing on village side and city side based on the load demand and the required voltage is transferred from village side to city side and vice versa

PROBLEM FORMULATION

In the absence of switches at different points in the distribution network, it is not possible to isolate certain loads when required. However, the circuit breakers are actually provided as a means of protection to completely isolate the downstream network in the event of a fault (short circuit, over load). Using this as a tool for load management is not desirable, as it disconnects the power supply to a very large segment of consumers and blackout over a large section of the distribution network. As we found that if the power in industries is disconnect for a minute is stops the production. So the power in industries should be continues. And when a line

man goes to repair the line then by unknowingly or wrong intentionally any one can ON the circuit breaker and line man can be met with fatal accident.

PROPOSED METHODOLOGY

The flowchart in illustrates Architectural block diagram of proposed “OTP based lineman security system”. In this proposed system whenever the lineman wants to take line clear (LC), he will send a OTP which is usually less than 256 as we are using 8 bit micro controller. We designed a system in such a way where line man sends OTP in

a format

„Q123DCT1“. This format represents a OTP where DCT stands for deactivation, 1 stands for feeder number and 123 is a 3 digit password that a lineman wants to generate. Here without the main authority permission, lineman cannot operate this function. Even though if he tries to do line charge without informing higher authority illegally, He will get caught because the high authority’s (AEE) number will be fed in the program so they will be having his complete information regarding line charge.

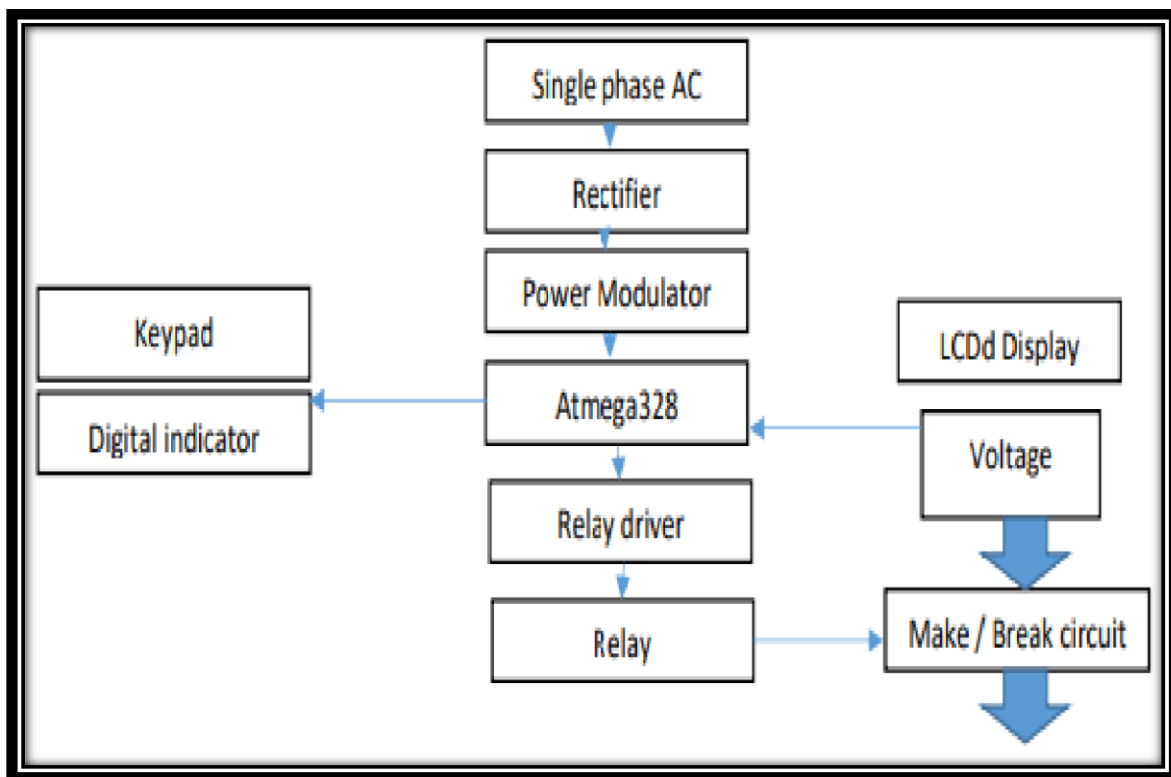

Fig 4.1 Architectural block diagram of proposed system

The flowchart in illustrates Architectural block diagram of proposed “OTP based lineman security system”. In this proposed system whenever the lineman wants to take line clear (LC), he will send a OTP which is usually less than 256 as we are using 8 bit micro controller. We designed a system in such a way where line man sends OTP in

a format

feeder number and 123 is a 3 digit password that a lineman wants to generate. Here without the main authority permission, lineman cannot operate this function. Even though if he tries to do line charge without informing higher authority illegally, He will get caught because the high authority’s (AEE) number will be fed in the program so they will be having his complete information regarding line charge

Block Diagram:

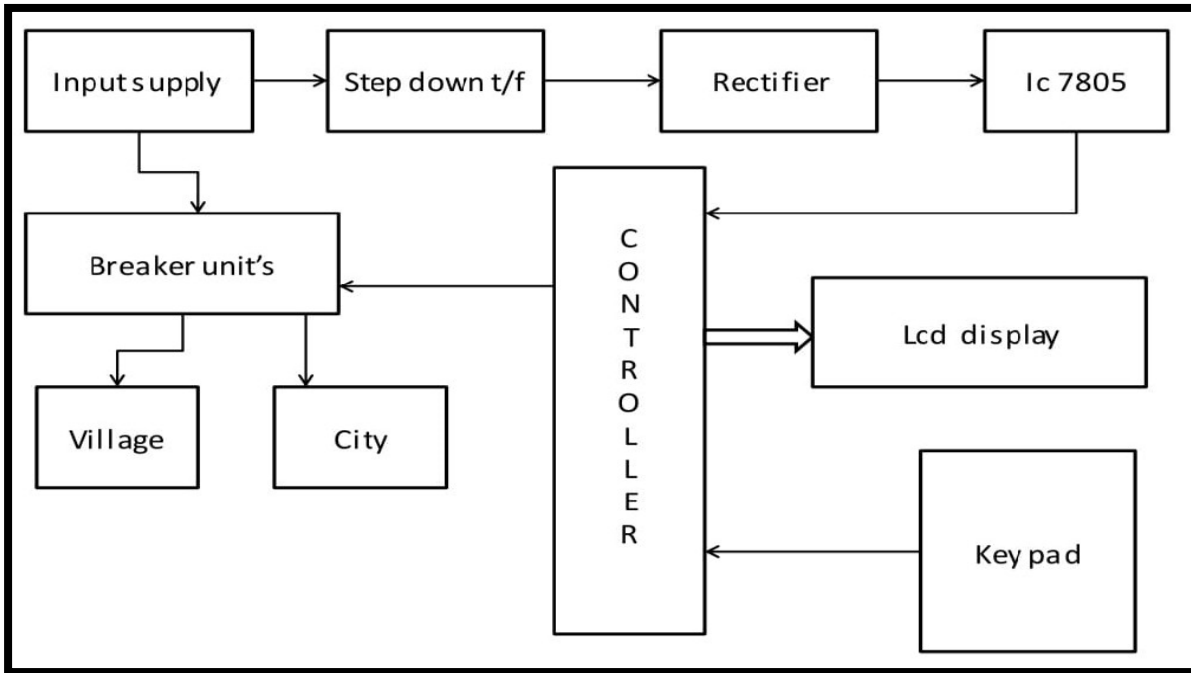

For the operation of circuit breaker through a password, program is written in keil software and created into a .hex file that is further burnt onto the controller with the help of

flash magic. Connections are given as per the circuit diagram. While giving the connections, it should be made sure that there is no common connection between AC and DC supplies.

WORKING

Circuit Diagram

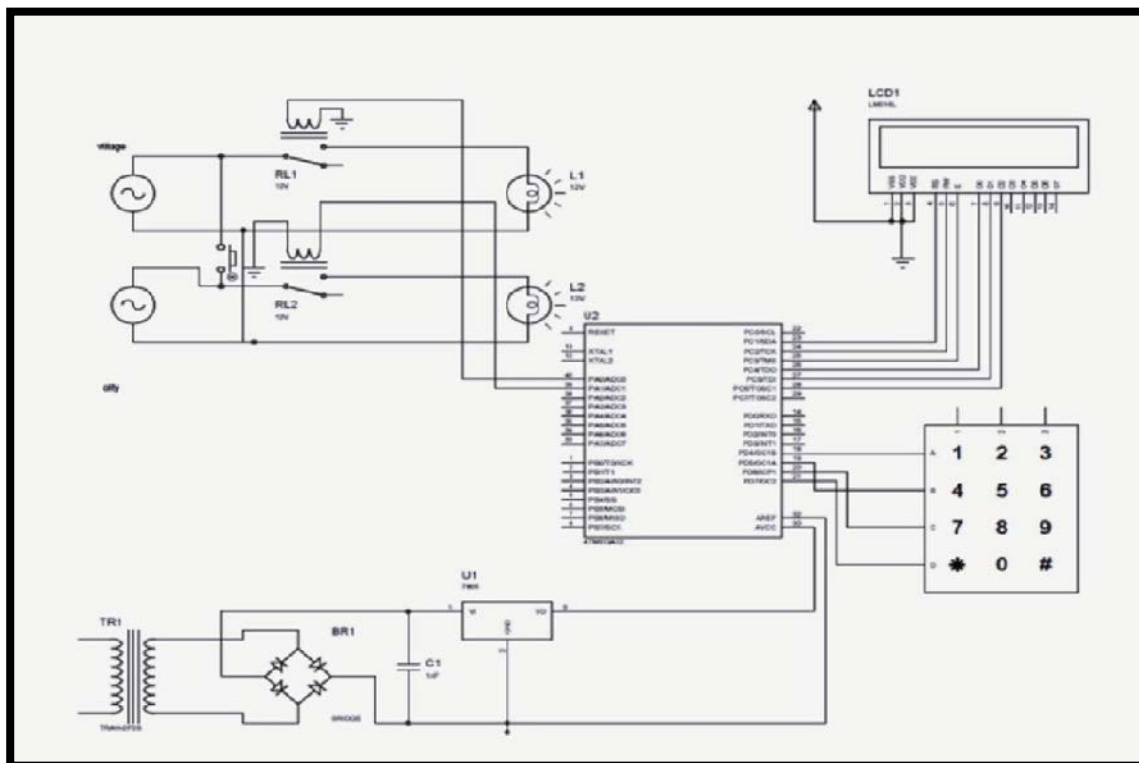

In this paper, the power is distributed over two sections. First one is supply unit and second one is Breaker unit. Supply unit is converted into 5v and is given to microcontroller. During maintenance maintainer may met with fatal accident. So, for protection of maintainer, relay is operated by password. This is done with the help of microcontroller. First of all the password is preset by programming. When we entered the password by the keypad if it is matched by preset password then the microcontroller sends a signal to trip the password based relay. And again when maintenance is done, password to be enter and if it matched with preset password, signal is send by microcontroller and relay ON. Village area and city area run by separate supply voltage. If the demand needed for either village or city area based on the available power is sharing between two area .The load demands is occurred, the maintainer entering the password to operate the switch the load will share, otherwise switch is opened.

Relay:

A relay is an electrically operated use an electromagnet to mechanically operate a switch, but other operating principles are also used, such as solid-state relays. Relays are used where it is necessary to control a circuit by a low complete electrical isolation between control and controlled circuits), or where several circuits must be controlled by one signal. The first relay long distance telegraph circuits as amplifiers: they repeated the signal coming in from one circuit and re transmitted it on another circuit. Relays extensively in telephone exchanges and early computers to perform logical operations. A type of relay that can handle the high power required to directly control an electric motor or other loads is called a contractor. Solid-state relays control power circuits with no moving parts, instead using a semiconductor device to perform switching. Relays with calibrated operating characteristics and sometimes multiple operating coils are used to protect electrical circuits from overload or faults; in modern electric relays ".



Lcd Display:

Term liquid crystal is used to describe a substance in a state between liquid and solid but which exhibits the properties of both. Molecules in liquid arrange themselves until they all point in the same specific direction. This arrangement of molecules enables the medium to flow as a liquid. Depending on the temperature and particular nature of a substance, liquid crystals can exist in one of several distinct phases. Liquid crystals in a nomadic phase, in which there is nospatial ordering of the molecules, for example, are used in LCD technology. Here this used to display the password entered by us to ON/OFF the circuit breakers.

Microcontroller:The ATmega32 is a low-power CMOS 8-bit microcontroller based on the AVR RISC architecture. By executing powerful instructions in a single clock cycle, the ATmega32 achieves throughputs approaching 1 MIPS per MHz, allowing the system designed to optimize power consumption versus processing speed. High-performance, Low-power Atmel AVR 8-bit Microcontroller advanced RISC Architecture. It have 131 Powerful Instructions, mostsingle-clock cycle execution. It contains 32×8 general purpose working registers. It is fully static operation. It is up to 16MIPS throughput at 16MHz. It is On-chip 2-cycle Multiplier. It is high endurance non-volatile memory segments. It contain 32Kbytes of In-system self-programmable flash program. The memory has 1024Bytes EEPROM, 2Kbytes Internal SRAM, Write/Erase cycles:10,000Flash/100,000 EEPROM, Data retention: 20 years at 85°C/100 years at 25°C.It is an optional boot code section with independent lock bits. In-System Programming by On-chip Boot Program. It is a True Read-Write Operation. It has a programming lock for software security. It is an Extensive On- chip Debug Support. It has Programming of Flash, EEPROM, fuses and lock bits through the JTAG Interface. It consists of capacitive touch buttons, sliders and wheels. It is up to 64 sense channels.

Keypad:

HEX keypad is a standard device with 16 keys connected in a 4x4 matrix, giving the characters 0-9 A-F. Interfacing of Hex keypad to Atmega32 is essential while designing embedded system projects which requires character or numeric input or both.

For example projects like digital code lock, numeric calculator etc. Here we are using this to enter numeric password for turn ON/OFF the circuit breaker. This can be easily interface with ant kits Microcontroller Development Board. It is a four pin tactile switch and four mounting holes 3.2mm each.

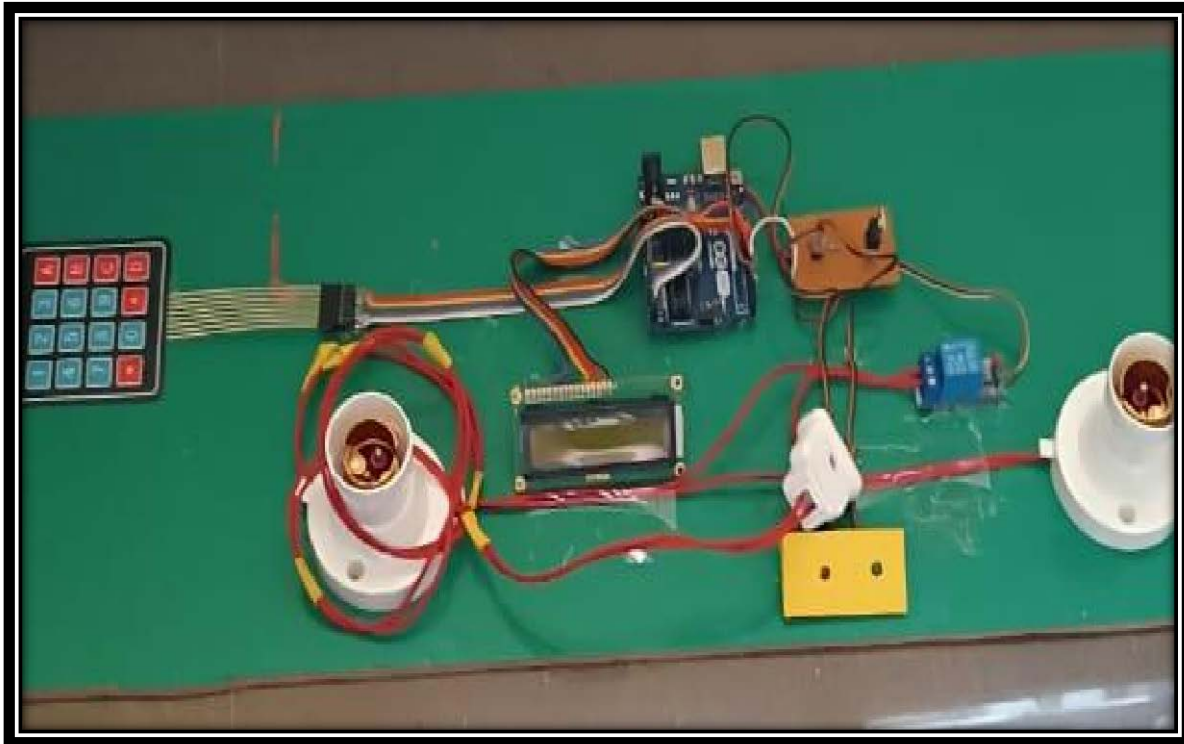
RESULTS & DISCUSSION

Fig 6.1 Electric pole and transmission line protection and Electric line men safety

This proposed system provides a solution, which can ensure the safety of the maintenance staff e.g. line man. The control to turn ON/OFF the line lies with the line man only. This system has an arrangement such that a password is required to operate the circuit breaker (ON/OFF). Line man

can turn off the supply and comfortably repair it, and return to the substation, then turn on the line by entering the correct password. Since it has the provision of changing the password, person can give any password of his will and have his work done safer.